

Ringwood

Design guidance and codes

Second draft report
November 2022
Minor amendments June 2023

Quality information

Prepared by	Check by	Approved by
Giuseppe Verdone	Ben Castell Director	NP Group name and position
Principal Urban Designer		

This document has been prepared by AECOM Limited ("AECOM") in accordance with its contract with Locality (the "Client") and in accordance with generally accepted consultancy principles, the budget for fees and the terms of reference agreed between AECOM and the Client. Any information provided by third parties and referred to herein has not been checked or verified by AECOM, unless otherwise expressly stated in the document. AECOM shall have no liability to any third party that makes use of or relies upon this document.

Contents

1	1. Introduction	5	4	4. Design guidance and code	33
	1.1 Introduction	5		4.1 Introduction	33
	What is a design code	5		4.2 Area-wide design guidance	34
	1.2 Objective	5		4.3 Applying the design guidance to character areas	73
	1.3 Process	6			
	1.4 Introduction to Ringwood	7			
	1.5 Key national and local reference documents	8			
2	2. Neighbourhood Area Context Analysis	12	5	5. Checklists	93
	2.1 Area of study	12		5.1 Checklists	93
	2.2 Settlement pattern and urban form	12			
	2.3 Heritage	14			
	2.4 Environment and landscape	26			
	2.5 Flood Risk	28			
	2.6 Character areas	20			
3	3. Understanding and responding to the context	31	6	6. Delivery	101
	3.1 Understanding and responding to the context	31		6.1 Delivery	101



Introduction

01

1. Introduction

Through the Department for Levelling Up, Housing and Communities (DLUHC) Programme led by Locality, AECOM was commissioned to provide design support to Ringwood Town Council.

1.1 Introduction

As the National Planning Policy Framework (NPPF) (paragraph 126) notes, 'good design is a key aspect of sustainable development, creates better places in which to live and work and helps make development acceptable to communities'.

Research, such as for the Government's Commission for Architecture and the Built Environment (now part of the Design Council; see, for example, The Value of Good Design¹) has shown that good design of buildings and places can improve health and well-being, increase civic pride and cultural activity, reduce crime and anti-social behaviour and reduce pollution.

This document seeks to harness an understanding of how good design can make future development as endearingly popular as the best of what has been done before.

Following an analysis of the Parish and good practice, those elements of good design are set out clearly as design principles which any development within Ringwood Parish should follow in order to comply with this Design Guidelines and Codes document.

1. <https://www.designcouncil.org.uk/sites/default/files/asset/document/the-value-of-good-design.pdf>

What is a design code

The Government's Planning Policy Guidance defines design codes as:

*'... a set of illustrated design requirements that provide specific, detailed parameters for the physical development of a site or area. The graphic and written components of the code should be proportionate and build upon a design vision, such as a masterplan or other design and development framework for a site or area. Their content should also be informed by the 10 characteristics of good places set out in the National Design Guide. They can be ...appended to a Neighbourhood Plan...'*²

1.2 Objective

The NPPF 2021, paragraphs 127-128 states that:

'Plans should, at the most appropriate level, set out a clear design vision and expectations, so that applicants have as much certainty as possible about what is likely to be acceptable. Design policies should be developed with local communities so they reflect local aspirations, and are grounded in an understanding and evaluation of each area's defining characteristics. Neighbourhood planning groups can play an important role in identifying the special qualities of each area and explaining how this should be reflected in development, both through their own plans and by engaging in the production of design policy, guidance and codes by local planning authorities and developers...'

2. Paragraph: 008 Reference ID: 26-008-20191001 - Revision date: 01 10 2019.

'To provide maximum clarity about design expectations at an early stage, all local planning authorities should prepare design guides or codes consistent with the principles set out in the National Design Guide and National Model Design Code, and which reflect local character and design preferences. Design guides and codes provide a local framework for creating beautiful and distinctive places with a consistent and high quality standard of design. Their geographic coverage, level of detail and degree of prescription should be tailored to the circumstances and scale of change in each place, and should allow a suitable degree of variety.'

The general design guidance and codes are intended to inform the design of homes which come forward on these sites as well as through any speculative proposals.

It is intended that the Design Guidelines and Codes report becomes an integral part of the Neighbourhood Plan and be given weight in the planning process.

This document has been prepared as a companion document to New Forest District Council's Ringwood Local Distinctiveness Supplementary Planning Document. It does not attempt to duplicate the analysis or guidance in that document, but to add depth and illustration. Applicants for planning permission will be expected to refer to both documents.

1.3 Process

Following an inception meeting and a site visit with a member of the Neighbourhood Plan Steering Group, the following steps were agreed with the Group to produce this report:

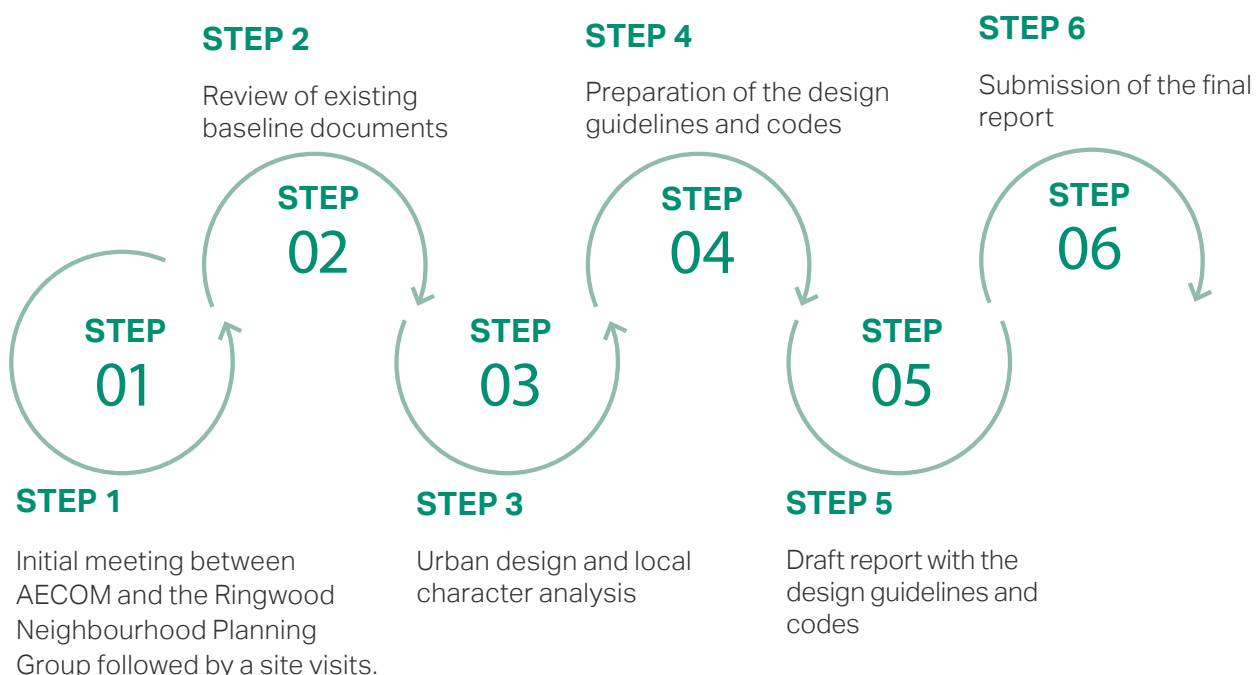

1.4 Introduction to Ringwood

Ringwood is one of the largest towns in the New Forest District, and it is located on the western edge of the New Forest National Park, at the eastern bank of a crossing point of the River Avon.

This strategic location has been key in influencing and shaping the development of the town. To its north, Blashford Lakes consist of sand and gravel works, while to the south and east high quality agricultural land is dominant. To the west and north are the Cranborne Chase and West Wiltshire Downs Areas of Outstanding Natural Beauty.

Part of the Parish falls within the boundaries of the national park and it is only ten miles to the New Forest Heritage Coast.

The town's location on the A31 provides easy access to Bournemouth and the cities of Southampton and Salisbury.

The town is comprised of three wards, Ringwood North, Ringwood South and Ringwood East.

The three wards are distinctively different, Ringwood North being mainly residential, Ringwood South housing most of the industrial estates and the town centre, and Ringwood East and Sopley being more rural.



F.1

Figure 01: Ringwood Context Map.

1.5 Key national and local reference documents

The following documents have informed this document. Some of these guidelines have been produced at national, district or parish level.

Any new development application should be familiar with these documents and make explicit reference to how each of them is taken into account in the design proposals.

2021 - National Planning Policy Framework

DLUHC

The National Planning Policy Framework sets out the Government’s planning policies for England and how these should be applied. It provides a framework within which locally-prepared plans for housing and other development can be produced.

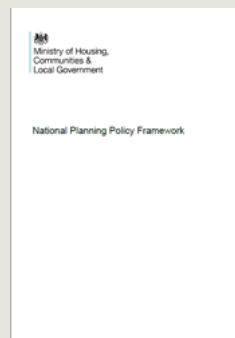

2021 National Model Design Code

DLUHC

This report provides detailed guidance on the production of design codes, guides and policies to promote successful design. It expands on 10 characteristics of good design set out in the National Design Guide.



2020 - Building for a Healthy Life

Building for a Healthy Life (BHL) is the new (2020) name for Building for Life, the government-endorsed industry standard for well-designed homes and neighbourhoods. The BHL toolkit sets out principles to help guide discussions on planning applications and to help local planning authorities to assess the quality of proposed (and completed) developments, but can also provide useful prompts and questions for planning applicants to consider during the different stages of the design process.



2007 - Manual for Streets

Department for Transport

Development is expected to respond positively to the Manual for Streets, the Government's guidance on how to design, construct, adopt and maintain new and existing residential streets. It promotes streets and wider development that avoid car dominated layouts but that do place the needs of pedestrians and cyclists first.

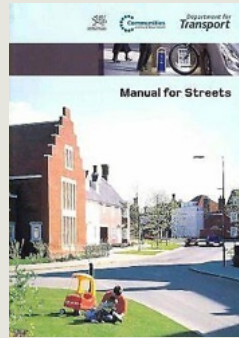

2020 - New Forest Local Plan

New Forest District Council

The Local Plan sets out a strategy and policies for the use, development or protection of land and buildings in the Plan Area for the period 2016 to 2036. The Plan Area is those parts of New Forest District outside the New Forest National Park.

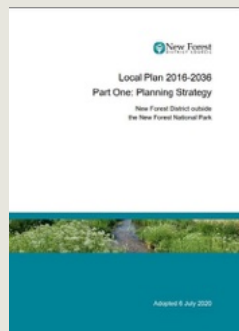

2013-Ringwood Local Distinctiveness SPD

New Forest District Council

This report provides guidance on how new development (including alterations or extensions to existing buildings) should be undertaken in the future, to ensure that it takes place in a way that protects local character and maintains the positive features that contribute to the particular area's local distinctiveness. It is a key companion to this document.

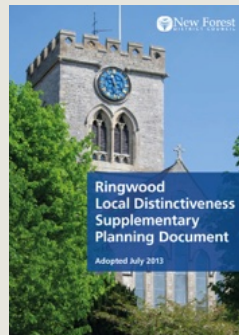

2022-New Forest National Park SPD

New Forest National Park

The aim of this Design Guide is to provide advice to help achieve high standards of design in development proposals while retaining and enhancing the distinctive character of the New Forest National Park.



2019 - New Forest National Park

New Forest National Park Authority

The Local Plan contains a succinct suite of policies to conserve and enhance the rich natural and built environment of the New Forest and its nationally protected landscape; and to retain the local distinctiveness of the area. The focus of new development is on catering for the needs of local communities within the National Park, including providing affordable housing for local people and support for a sustainable economy.

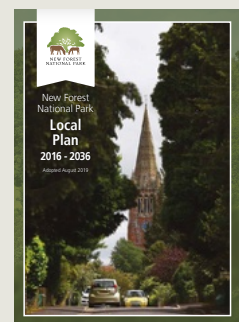

2003 - Ringwood Conservation area appraisal

New Forest District Council

This conservation area appraisal provides supplementary planning guidance on the subject of the design of development in Ringwood's conservation area. It does so by assessing and analysing the character of the conservation area, and then setting down what implications that has for future development. The appraisal amplifies the policies of the New Forest District Local Plan.

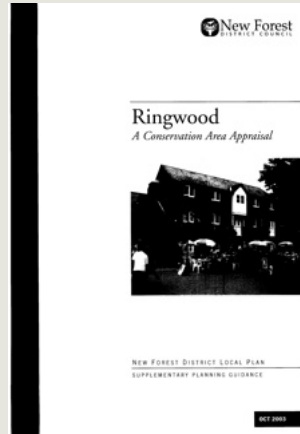

2003 - Shopfront Design Guide

New Forest District Council

This document provides Supplementary Planning Guidance on the subject of the design of shopfronts. It amplifies the policies of the New Forest District Local Plan.



2006 - Housing Design, Density and Character SPD

New Forest District Council

The aim of this Supplementary Planning Document is to promote good design in new residential development and ensure that new residential development respects local character and identity.

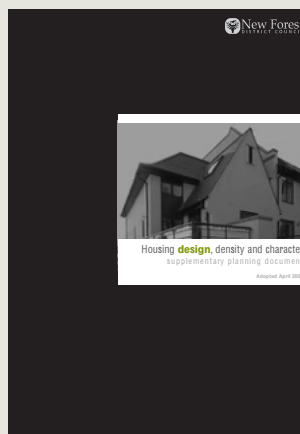



Neighbourhood Area
context analysis

02

2. Neighbourhood Area context analysis

2.1 Introduction

This section outlines the broad physical, historical and contextual characteristics of Ringwood. It analyses the area's settlement pattern, heritage, landscape and environment and sets out the key features of each component. It provides a high level overview, with more detail being found in the district level documents referred to in the previous section.

2.2 Settlement pattern and urban form

The historic market town of Ringwood is located on the western edge of the New Forest at a crossing point of the River Avon. It is well connected by road to a number of cities and towns including Southampton and Bournemouth.

The town's medieval settlement plan remains partially legible owing to the survival of the long and narrow plots, which resemble burgage plots, concentrated around the principal historic streets. High Street, West Street, Christchurch Road and Southampton Road form Ringwood's historic core. A number of older lanes remain throughout the town despite recent urban growth. Many of these lanes are valued as distinct features which echo rural tradition and valuable individual character. These lanes provide an opportunity to enhance pedestrian links within the town centre.

Following the arrival of the railway, the town expanded eastwards of the historic centre in an unusual and more sporadic development

pattern around a network of suburban routes. As result, the footprint of the town has broadened as a patchwork of a planned pocket houses. This pattern has continued over the years, resulting in a mixture of commercial and residential development of different ages and styles, adding to the particular and distinctive character of the town. This patchwork has enabled roads, such as the main A31 Ringwood bypass and the Mansfield Road, to be constructed with relatively little demolition of the neighbourhood.

Despite this, the construction of major highways has been detrimental to historic character, having contributed to the loss of focus upon the town's historic core and severed relationships between heritage assets. Recently, with the introduction of Mansfield Road as a link road relieving the centre of its through-traffic, has altered the traditional pattern of the town centre and has created a distinct mismatch between buildings and streetscape.



Figure 02: 872 6-inch OS map of Ringwood showing the principal historic streets.

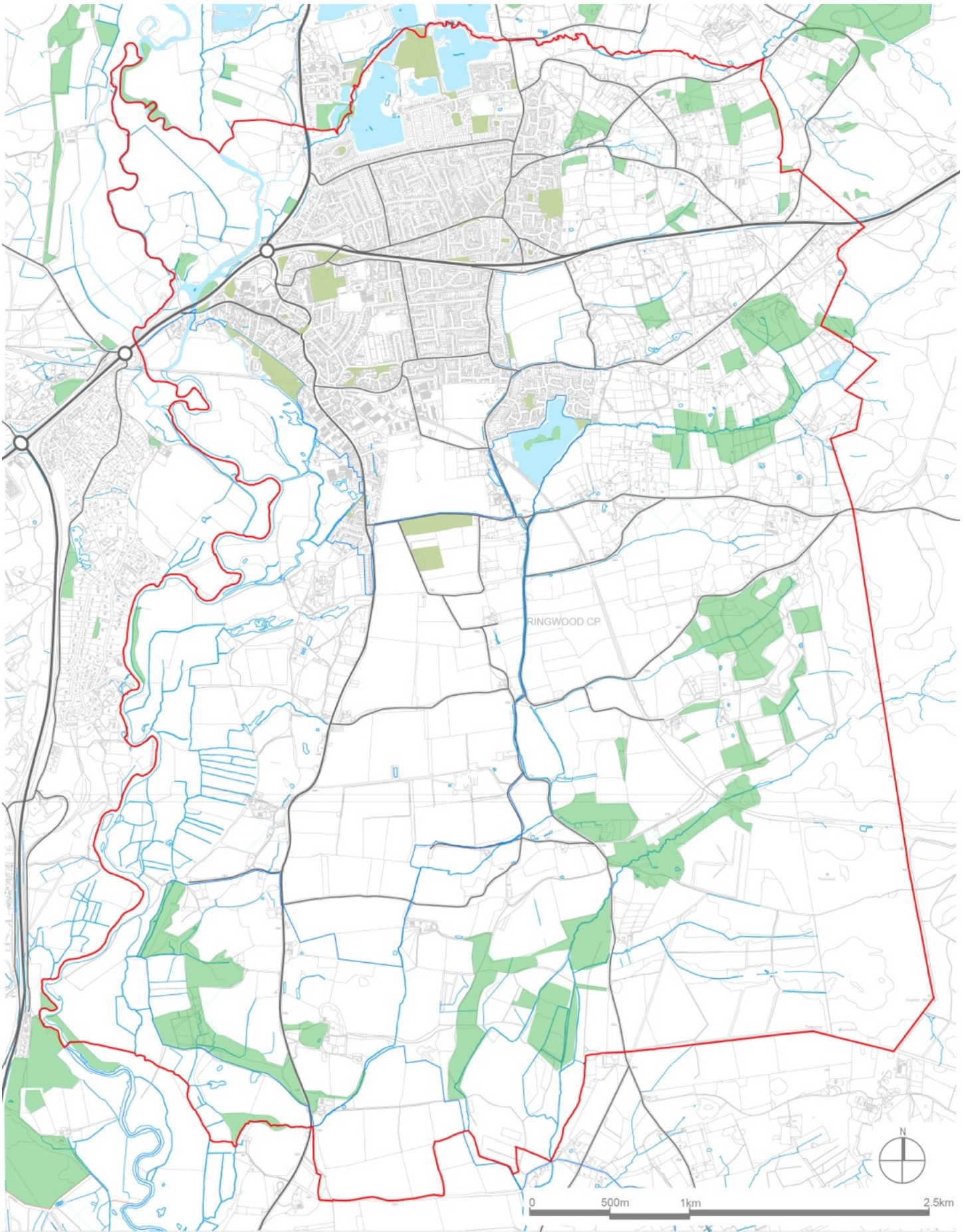

Key

- Ringwood Neighbourhood Area
- Woodland
- Public Open space
- Road Network
- Water
- Buildings

2.3 Heritage

Ringwood Conservation Area was first designated in 1970, its boundary has since been extended and now covers areas outside of the historic core. The conservation area contains the commercial town centre and various areas of mixed-use development. There are many high-quality historic buildings on the High Street and Market Place. Special architectural character is generally attributed to groups of uniform and architecturally inconspicuous buildings, all modest in scale. In this respect both High Street and Market Place are considered to have merit as cohesive areas of townscape.

There are no medieval buildings in Ringwood, the oldest building material in a domestic structure is in the Old Cottage Restaurant (NHLE 1094979) grade II which dates to the 16th century. The historic building stock predominantly dates to the 18th century and is modest in scale limited to two storeys in height. There are a few large 18th and 19th century townhouses which are three storeys in height such as Greyfriars (NHLE 1302635) grade II. Most 19th century and early 20th century are a continuation of the style and form of earlier development with the main exceptions of the Old Cinema which occupies the plot of the former Corn Exchange.

There are a number of different building materials which appear throughout the conservation area, the most common of which is red brick. A number of brick facades are painted or rendered in neutral colours.



Figure 04: The Jubilee Lamp (NHLE 1350931) grade II.



Figure 05: The Old Cottage Restaurant (NHLE 1094979) grade II.

Roofs are typically pitched with slates or clay tiles, gabled dormers are common along High Street and Christchurch Road. There is little use of stone except for the Parish Church (NHLE 1094964) grade II* and the occasional use for dressings. Until the 20th century there were no purpose-built shop premises, the majority of shopfronts within the conservation area are inserted into earlier buildings. Sash windows are most common, although a number have been replaced with modern casements.

There are no distinct recurring architectural features of particular local importance to Ringwood. Three buildings have mathematical tiles which are of architectural interest. Decorative architectural features of merit also include the iron balcony railings at Grove House, the Venetian window at the Old Bank House and the pedimented doorcase at Netherbrook House, Christchurch Road.

Recent development within the conservation area is considered detrimental to character where it negatively impacts the setting of historic buildings or does not relate to the historic building pattern. New development or redevelopment should not exceed the precedent in scale set by the historic building stock. There is no set palette of vernacular materials that developers should follow, instead development should be carefully considered on an individual basis taking into account the settings of nearby heritage assets.

Ringwood Conservation Area includes over



Figure 06: Bickerley Terrace .



Figure 07: 22-24 High Street.

70 listed building of different ages. Of these listed buildings, several are considered local landmarks and have a key role in defining local character. These assets include:

- The Church of St Peter and St Paul (NHLE 1094964) grade II*, rebuilt in 1853 re-using earlier stone . The chancel was designed as an exact replica of the 13th century one.
- The Meeting House (NHLE 1094968) grade II*, dated 1727. The Meeting House is a very good example of an early non-conformist chapel complete with box pews, now used as an exhibition centre and local history museum.
- Clark’s Almshouses (NHLE 1350934) grade II were built in 1833 in the Tudor Revival style. The almshouses were the first building in Ringwood recorded as having a damp proof course and cavity walls.
- Old Bank House, 18–20 Market Place (NHLE 1350929) grade II is one of three buildings in Ringwood which features mathematical tiles in its frontage.

In addition to the listed buildings, various non-designated buildings are considered to have historic and architectural merit within the village. In particular the Letchers (24 market place), the former Town Hall, Corn Exchange and Courthouse, Bickerley Terrace – are identified as buildings of local significance.



F.8

Figure 08: Church of St Peter and St Paul, Ringwood.



F.9

Figure 09: The Meeting House.

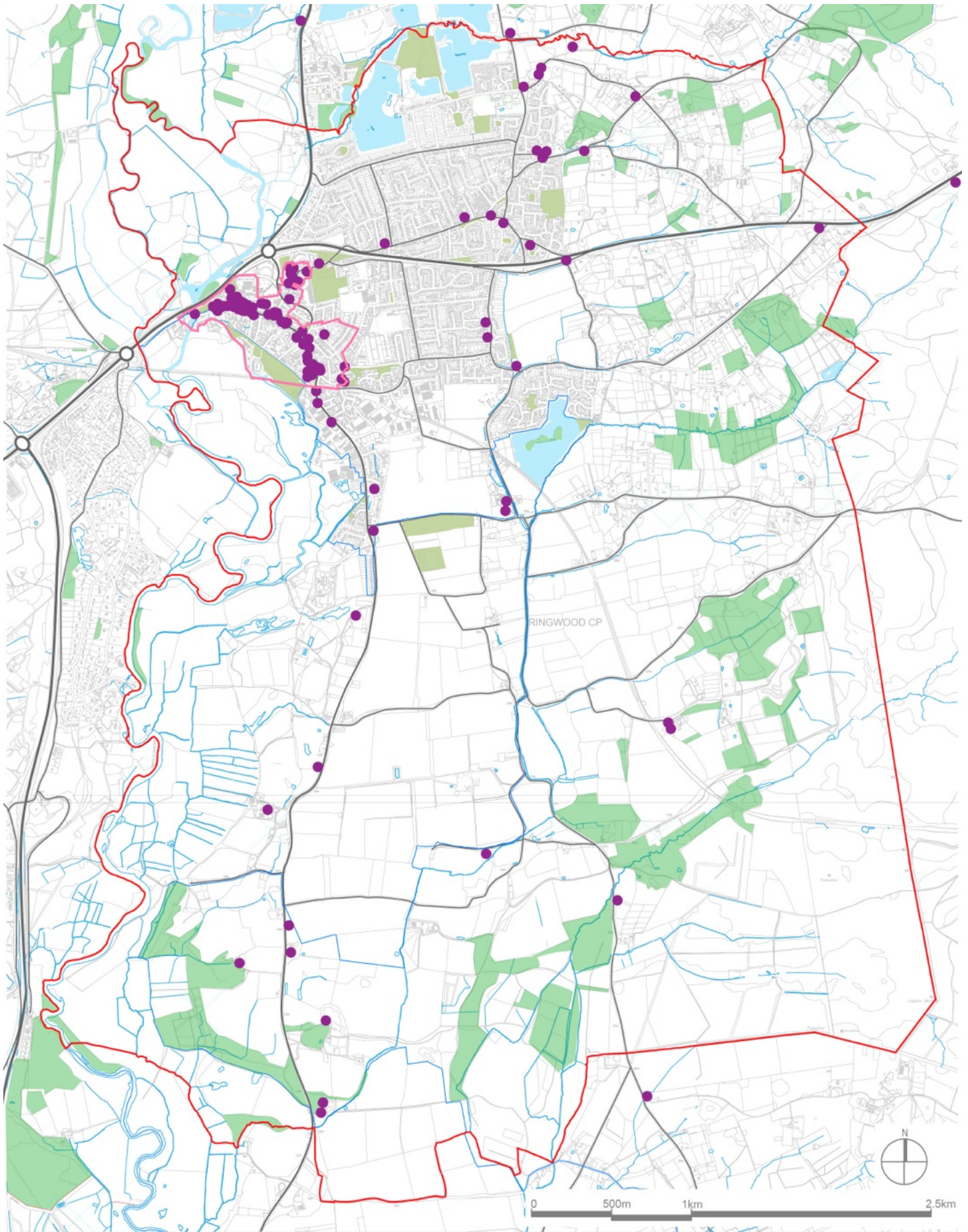

Key

Ringwood Neighbourhood Area	Woodland	Road Network	Listed Building
Water	Public Open space	Buildings	Public Open space

F.10 | **Figure 10:** Ringwood Heritage map.

Selected notable heritage assets

Historic buildings have been incorporated to good effect in the Furlong Shopping Centre (figure 11).

Market Place, close to the mid-19th century Church of St Peter and St Paul, contains two of the few classically designed buildings in the town, the grade II listed Pearsons (now The Old Bank House, 12) and Church Hatch House (13). 24 Market Place is a red brick building with terracotta detailing that has been marred by modern extensions at each end (14).

Although it is short, West Street contains interesting buildings such as No 17 with its studded six-panelled door, hornless sashes and Dutch gable (15); Bridge House (16) with its Doric doorcase, pediment and fanlight (19); and Monmouth House where the Duke of Monmouth was held after the battle of Sedgemoor (17, 18). All are grade II listed apart from Bridge House, grade II*. A rare example of pargetting (which includes the date 1928) can be found on No 31/33 West



F.11



F.12



F.13



F.14



F.15



F.16

Street, a building otherwise spoiled by poor fenestration and inappropriate signage. Opposite, The Old Cottage Restaurant (21) is a thatched former row of cottages dating to the 16th century and is representative of how the town would have looked in that period. The early 19th century Fish Inn (22) and the bridge over the River Avon (23, both grade II) would have provided a characterful entrance to the town prior to the construction of the bypass.



F.17



F.19



F.18



F.20



F.21



F.22



F.23

Bickerley Terrace (24, 25) is an impressive row of red brick and slate cottages built in 1882. The row is characterised by the massive chimney stacks in the roof slopes but has suffered from the majority of the windows and doors. The semi-detached cottages on Riverside (26) are slightly later but make good use of multi-coloured brick. The two rows were the first to be built on Bickerley Common which continues to be an important open space within the town boundaries (27). The electricity substation at the southern end of the common (28) is attractively designed with its timber panelled door and use of tiles.

Coxstone Lane is the location for four of the town's few thatched cottages, all listed grade II (29 to 33). Christchurch Road exemplifies Ringwood's eclectic in style with large, ornate 19th century villa at Nos 69 and 71 (34) and a row of thatched cottages with later shopfronts (35, 36). At No 86 Netherbrook House is a classical 18th century building (37) while Nos 59 and 61 (38) are modest early 19th century cottages in red brick with fanlights and hornless sash windows. The single storey

Ringwood Library (39) is a rare (and good) example of modernism within the town and is juxtaposed with the grade II listed 18th century Greyfriars, one of only a few three storey buildings in the town and the cream brick Methodist Church with its tall and slender spirelets.



F.24



F.25



F.26



F.28



F.27



F.29



F.30



F.31



F.32



F.33



F.34



F.35



F.36



F.37



F.38



F.39

Woodstock Lane is an unadopted road that contains two rows of cottages with square bays and hung tiles (40, 41) and four pairs of semi-detached house built in the multi-coloured brick used at Riverside. Quomp has a more suburban feel with mainly inter-war semis and contains (on the corner with Hightown Road (42) one of the few Arts and Crafts inspired houses in the town. The suburban feel continues into Hightown Road although the street also contains the early 18th century Southend House (43) in brick and render.

While the former Southampton and Dorchester Railway closed in 1964 and the station was demolished soon after 1973 there are reminders of its presence in The Railway public house (44); a trackside building (45) now a garden machinery store and in other light industrial buildings in the triangle formed by Hightown Road, Christchurch Road and Castleman Way. The decorative bargeboards and window arches of No 19 Hightown Road remain particularly attractive features.

Christchurch Road has two timber framed buildings at Rose Cottage/The Match Box (47) and Candlestick Cottage (48), both grade II listed.

College Road is characterised by sizeable semi-detached and detached late 19th and early 20th century houses, mostly in red brick (49).



F.40



F.41



F.42



F.43



F.44



F.45

On Southampton Road the mid-18th century Red House (grade II, 50) is flanked by two starkly modern buff brick blocks containing four flats each. Continuing towards the town on the south side of Southampton Road is Carvers House (51, grade II) an early 19th century row of three cottages and a small house.



F.46



F.47



F.48



F.49



F.50



F.51



F.52



F.53



F.54

The eclectic nature of Ringwood's architecture continues here with Elmsdown Court (52), a mid-20th century development in the Garden Suburb style. Opposite stands the 18th century Manor House (grade II*) with its 18th and 19th century wings (grade II, 53) and stable block (grade II, 54). Contemporary with the Manor House is the grade II listed Bumblebee Cottage and The Cottage, both in rendered brick (55). A little later, the grade II listed early 19th century Mansfield House (56) and its Coach House are located just outside the core of the historic town. The southern end of Southampton Street comprises mainly 20th century buildings but these give way to historic buildings when the High Street is reached with the 18th and 19th century Crown Hotel (57) and other red brick, painted brick and rendered buildings around Friday Cross.

The extension to the Conservative Club (59) is one of the few starkly modern buildings in the town centre. As the historic core is left behind Christchurch Street becomes less commercial and more residential although a row of former workshops (60) survives at No 28 with a Methodist Chapel (61) between

Nos 32 and 34.

The High Street has a very fine grain (67) and both it and Market Place have to be walked to pick out the features of interest. Not least among these is the impressive Original White Hart at (grade II, 69) and the equally impressive if incongruous former Corn Exchange (68), both in Market Place. One of



F.55



F.56



F.57



F.58



F.59



F.60

the few modern buildings, the Nat West bank at No 11 High Street (74) manages to sit comfortably amongst its older neighbours. Both the High Street and Market Place have retained a number of attractive shopfronts including those at Nos 35 & 37 (62) and 57 & 59 (63) High Street and 1 (66); 13 (70) 23 (71) and 27 & 29 (72) Market Place.



F.61



F.62



F.63



F.64



F.65



F.66



F.67



F.68

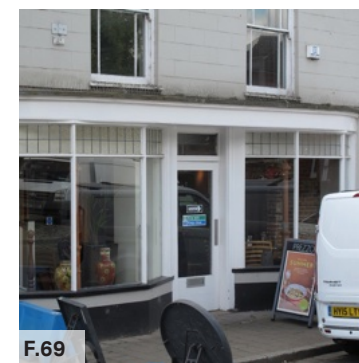

F.69

2.4 Environment and landscape

The peculiar underlying landscape of Ringwood is enriched of very special habitats and ecology. Made up on beds of river valley gravel, the topography is generally flat, offering wide long distance views.

To the west of the town, floodplains and various watercourses, ditches, drains and meadows dominate the landscape and are part of the Green Belt and the Site of Special Scientific Interest areas.

To the east, the village, is framed by the New Forest National Park. The land rises up through well wooded farmlands towards the ancient forest farmlands and the higher plateau of the New Forest heathlands.

To the north, the landscape is characterised by a series of lakes (Blashford Lakes) formed by recent gravel extraction, which alongside with the watercourse itself, provide an environment of open water, wooded shores, wetland habitats and verdant agricultural land.

The southern boundary is characterised by a large expanse of coniferous plantation, broadleaved and mixed woodlands, forestry scrub and new tree planting.



F.70

Figure 70: New Forest Copse, Ogdens



F.71

Figure 71: New Forest Pond & Heath, Ogdens

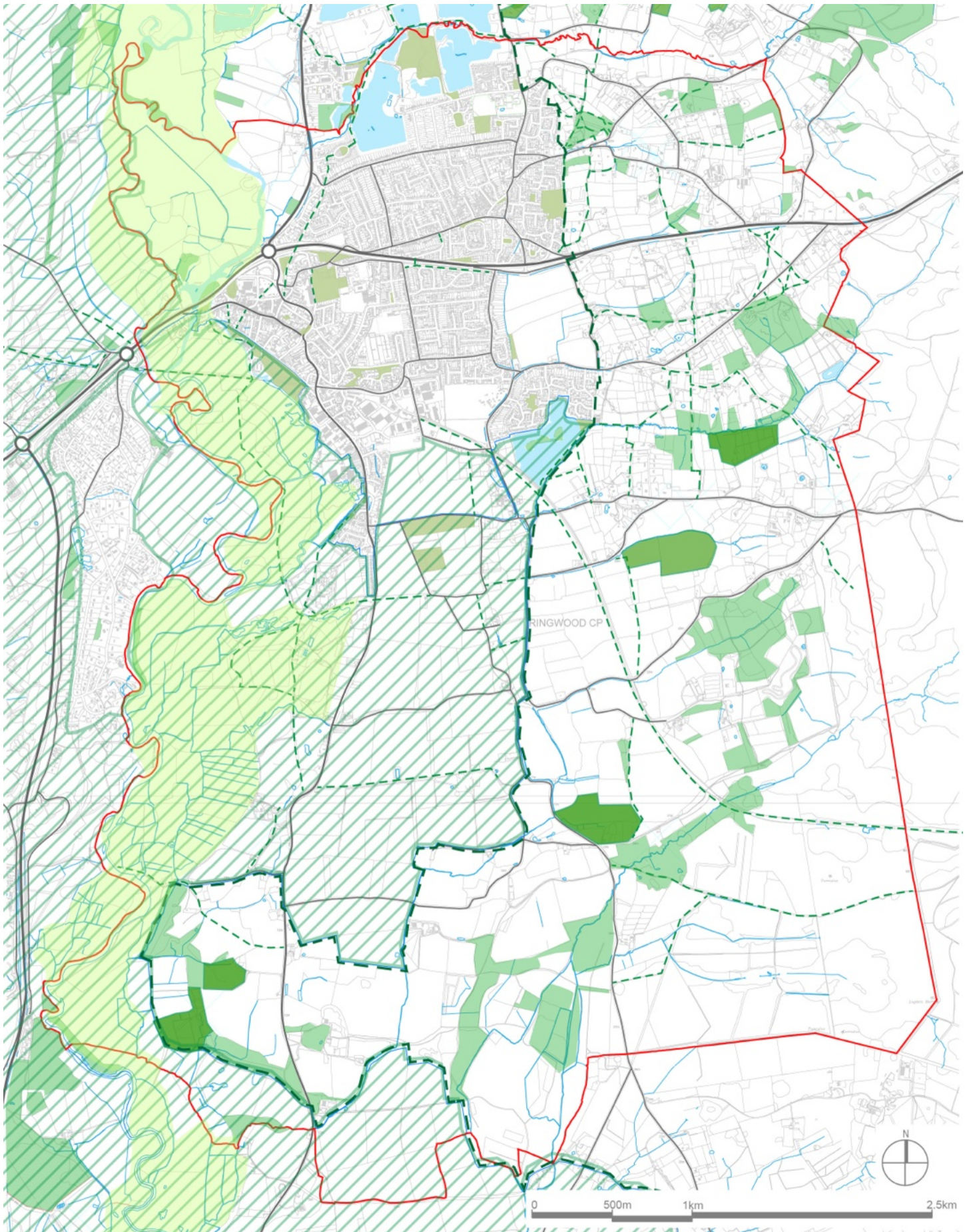

Key

Ringwood Neighbourhood Area	Ancient Woodland	Contours line	Public Open space
Water	Deciduous Woodland	New Forest National Park	Road Network
Site of Special Scientific Interest (SSSI)	Green belt	Public Right of Way (PRoW)	Buildings

F.72 | **Figure 13:** Ringwood Landscape and Environment map.

2.5 Flood risk

Significant parts of the Ringwood Parish is subject to some level of flood risk (mostly Flood Risk Zone 3).

The River Avon flows to the west of the Town, with Foulford Bottom and several unnamed drains located to the east and south-east, subject to Flood Risk Zone 3. Flood Risk Zone 2 also surrounds these watercourses in places, with areas of overland flow expanding as flood water flows out of bank.

Several properties in the south-west and east of the settlement lie within Flood Zone 2 or 3.

Other areas at risk include land affected by rainwater surface run-off, as surface water tends to pond in residential gardens and areas of open space in Ringwood.

Specific roads which are at risk of surface water flooding include the A31, Southampton Road, Gorley Road and Linford Road.



F.73

Figure 73: Toward the Town Centre from the Castleman Trail.



F.74

Figure 74: Looking South from the Castleman Trail.

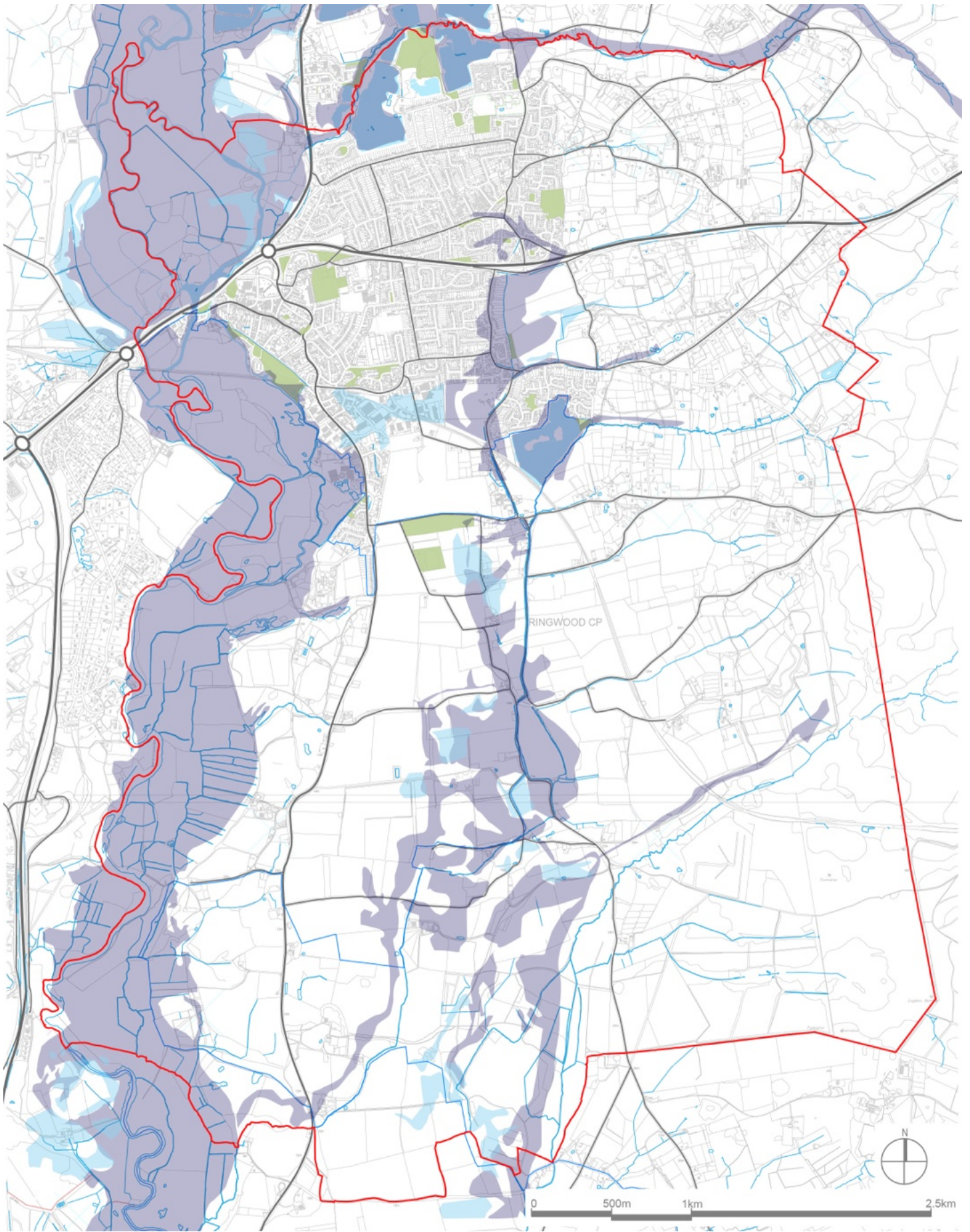

Key

- | | | |
|----------------------------------|-------------------|--------------|
| Ringwood Neighbourhood Plan Area | Flood Risk zone 2 | Buildings |
| Water Features | Flood Risk zone 3 | Road Network |
| Public Open space | | |



**Understanding and
responding to the context**

03

3. Understanding and responding to the context

3.1 Understanding and responding to the context

The key thing that all development in Ringwood should do is to respond to its context. The design guidance and codes in this document do not specify a particular architectural style - either traditional or contemporary styles may be appropriate in the right context, but Ringwood Town Council will expect all applicants to show how their proposals have been prepared based on an understanding of the particular characteristics of the site.

This section briefly introduces what the Town Council will expect to see accompanying planning applications. The expectation is the same for all applications but will be proportionate to the scale of the development.

Site analysis

All development proposals should start with a site analysis. Development never happens in isolation; there is always a context to respond to. This includes what is within the site itself and what surrounds the site.

A basic approach to a site analysis will include the following steps:

- Desk-based studies of topography, surrounding land uses, connections, designations, policies and more.
- Site visit to observe and assess the characteristics of the site. This can review things like existing buildings, vegetation, wet areas, potential wildlife activity and boundary conditions.
- Explore around the site, looking at, for example, access, connections, views, local facilities that people will want to use

and local character – heights, massing, materials, uses.

- Make sure all of this is recorded so that anybody reviewing a development proposal can understand what makes the site and its surroundings unique and the basis for the design decisions taken.

An important function of the site analysis is to distil what defines the special character of the site and the neighbourhood or area it forms part of.

Responding to context

The site analysis outlined above should form the basis of carefully considered design response. Those assessing designs will need to understand how the designer has:

- Shaped the proposals based on the site's natural features, topography, landscape and views, and the surrounding built environment. For example, how has a particular view been framed and how and why does the density and massing of development differ across the site?
- Connected the proposed development to existing routes (streets, footpaths, cycle paths) and facilities (shops, schools, employment, public transport).
- Crafted a bespoke vision and set of development principles for the scheme, particularly for larger developments.
- Larger schemes – which can be defined as those that require new streets to be constructed – will be expected to be guided by a masterplan. This should show the key structural elements of the design, including access, open space, development blocks and character areas.



Design guidance and
codes

04

4. Design guidance and codes

4.1 Introduction

The aim of this document is to ensure that future development within Ringwood is well-designed and built to last. This document focuses on the existing distinctive characteristics of the Parish, showing how they can be incorporated into new development, with the aim of maintaining and, where possible, enhancing the local ambiance.

Reference to existing character does not rule against contemporary approaches to design, but it does require a more nuanced and sensitive design approach to avoid inappropriate design solutions. The elements that are more general are what we mean by design guidance. Other elements that are more prescriptive or set out parameters are the design codes.

This chapter is divided into 2 further sections. Section 4.2 includes 9 design codes, shown on this page. For each, a short introductory text with more general design guidance is provided, followed by a series of more prescriptive codes and parameters highlighted in a light-green box.

The guidance and codes in section 4.2 is to be applied to Ringwood Parish (outside the National Park). . Section 4.3 includes more detailed guidance for three of the character areas identified in the Ringwood Local Distinctiveness SPD.

DC.01 Layout, grain and pattern of development

DC.02 Access and movement

DC.03 Relationship with the street and other spaces

DC.04 Shop fronts

DC.05 Development affecting heritage assets

DC.06 Building scale and form

DC.07 Architectural styles, materials and details

DC.08 Open space

DC.09 Sustainable design

4.2 Area-wide design guidance

DC.01 Layout, grain and pattern of development

DC.01.1 Layout and grain

Future developments should be sympathetic to local character and history, and establish or maintain a strong sense of place. Understanding and appreciating the local historic environment and the different character areas can help to ensure that potential new development is properly integrated with the existing settlement and does not result in the loss of local distinctiveness. Therefore, some guidelines for future development are:

- i. Development should sustain or enhance the characteristic and historic locally distinctive grain of development with its mix of form, layout and size;
- ii. Siting and layout of new development must be sympathetic to the character of the area and must respect the historic heritage of the town. Proposals near the historic part of the town should respect the characteristic medieval field patterns; and
- iii. Development which does not reflect the current grain of the town must be avoided. Proposals need to consider existing density and the relationship between buildings and plot sizes.



Figure 17: The town centre character area is characterised by a typical rhythms and relatively consistent key dimensions along the town centre streets.

DC.01.2 Pattern of development

Any future development should reflect the local context ensuring that it makes a positive contribution to the existing built form.

To ensure a good fit between new and old it is important that any new development seeks to conserve and enhance the character of the existing settlement in terms of urban form, as well as character. Therefore, some guidelines for new development are:

- i. Development affecting the transitional edges between a settlement and the surrounding countryside must be softened by new landscape planting to provide a more harmonious interface between built development and the wider landscape;
- ii. Development should seek to strengthen frontages along routes between the town centre and green spaces & riverfront to encourage exploration & active modes of transport
- iii. Development that alters the existing roofline or blocks existing long distance views to the riverfront should be avoided; and
- iv. New development should be limited in extent and well-integrated with the landscape and the existing settlement pattern and vegetation.



Figure 18: Example of recent development which respects the existing grain of the immediate setting.

DC.02 Access and movement

DC.02.1 Roads

The street layout in Ringwood reflects the historic origins at its core, as well as its later town character and modern development. The A31 and A338, running from east to west and north to south respectively, are the principal routes which connect the town to the surrounding settlements. Branching out are mostly connected streets leading to the town centre and the residential areas. There are some cul-de-sacs in residential neighbourhoods, whilst public rights of way provide connections to the surrounding countryside.

Street design for new development should adopt an interconnected street layout, to allow traffic to be distributed more evenly across the network and reduce congestion. A connected street network would encourage the use of active travel including walking and cycling and would generate a higher level of pedestrian activity. This would promote chances of social interactions and enhance natural surveillance at street level while promoting accessibility of services and emergency vehicles. Some guidelines for future development are:

- i. Street layouts within development sites should be connected where possible and should connect to the wider area and to public footpaths;
- ii. Street hierarchy must be clear and legible. Main, secondary streets and private lanes have different character, in terms of width of carriageway, pavement, parking spaces, street trees) and can therefore, support different levels of traffic;

- iii. Street design must incorporate opportunities for landscaping (street trees and green verges) and sustainable drainage solutions (e.g. bioretention trees);
- iv. Larger schemes can incorporate variety but layouts must be legible and easy to navigate. Strong street character is preferable to curvilinear roads with too much variety;
- v. Opportunities for cycling should be provided, where possible, taking into account the narrow streets; and
- vi. New development should include streets that incorporate the needs of pedestrians including disabled people with electric buggies. In particular, pavements should be wide enough to allow for the latter to move easily, whilst traffic calming measures, like raised tables or crossings, should be introduced along the carriageway.



Figure 19: Footpaths should be an integral part of the design to encourage alternative ways of transport.

Residential streets

Residential streets have a strong residential character and provide direct access to residences from the secondary roads. They must be designed for low traffic volumes and low speed. The lane width can vary to discourage speeding and introduce a more informal and intimate character. Variations in paving materials and textures can be used instead of kerbs or road markings. The design guidelines for this street typology are:

- i. Carriageways must accommodate two-way traffic and footways with a 2.00m minimum width on either side, where possible, to meet the needs of a wide range of people including those with disabilities and with electric buggies;
- ii. Green verges and street trees should be integrated in the design, where possible, to improve the visual result and create good quality neighbourhoods;
- iii. Residential frontages should be accommodated with rich vegetation and planting in order to provide a virtual separation between public and

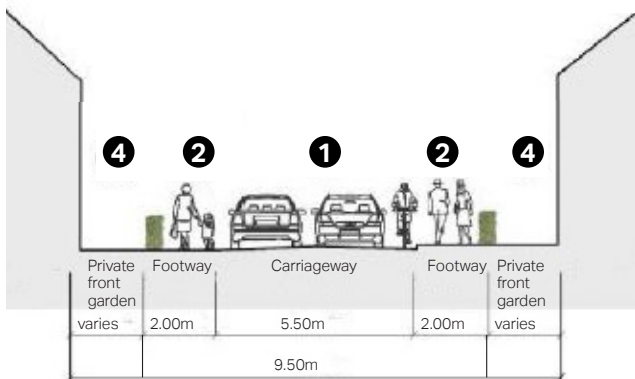

Figure 20: Section showing indicative dimensions for residential streets.

private spaces and secure privacy for the owners;

Private drives

Lanes and private drives are the access-only types of streets that usually serve a small number of houses. The design guidelines for this street typology are:

- i. Lanes and private roads should be minimum 6.00m wide and serve all types of transport modes including walking and cycling, and allow sufficient space for parking manoeuvre; and
- ii. Opportunities to include green infrastructure, hedges, and/or private gardens to soften the edges must be maximised.

- 1 Shared carriageway (neighbourhood traffic). Traffic calming measures may be introduced at key locations.
- 2 Footway.
- 3 Green verges and street trees.
- 4 Residential frontage with boundary hedges and front gardens.

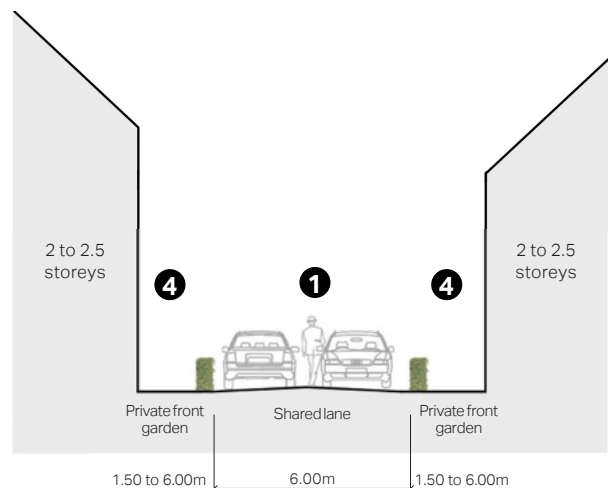

Figure 21: Section showing indicative dimensions for lanes and private drives.

Main streets

This street provides the main access spine of a new development and connects it to the rest of the settlement. It will carry most of the heavy traffic, whilst the rest of the street network will only carry low neighbourhood traffic. The design guidelines for this street typology are:

- i. Main streets should promote the existing context by preserving any type of characteristic features, i.e. green assets ;
- ii. Provide front gardens and street planting along the main streets to contribute to the general feeling of openness in the area;
- iii. Where possible, locate parking to the side of properties and consider using garages to mitigate the impact of cars on the streetscape. Planting and vegetation on the front gardens and sides of the properties can also

help improve the aesthetics of the environment;

- iv. Planting on street corners, junctions, and at the end of vistas can help with wayfinding and serve as open spaces in their own right;
- v. Green verges and street trees should be integrated in the design, where possible, to create attractive neighbourhoods and provide shade to pedestrians and cyclists;
- vi. Where on-street parking is proposed, it should be interspersed with trees to mitigate visual aspect of parking; and
- vii. Cycle lanes are encouraged on main streets to promote alternative methods of transportation.

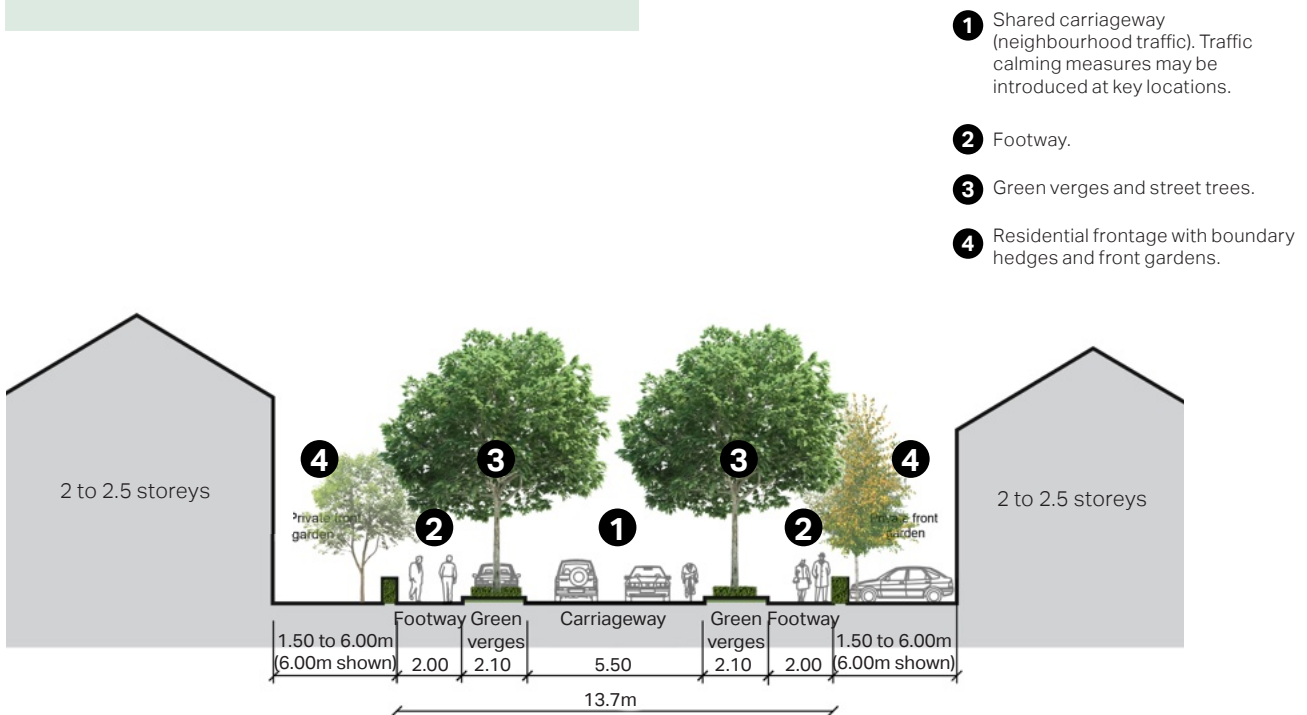

Figure 22: Section showing indicative dimensions for residential streets with green verges.

DC.02.2 Parking

Residential Parking

The demand for private cars still remains high, at the time of writing, and therefore car parking has to be carefully integrated into neighbourhoods. A good mix of parking types should be deployed, depending on, and influenced by location, topography and market demand. The main types to be considered are shown in this section.

A very useful website that helps define appropriate car parking solutions depending on the type of development is <http://www.spacetopark.org/>. This resource should be used as a design tool in new developments.

- i. Vehicle parking should be mainly provided on-site. In general, the approach to the provision of parking should be flexible not only with the types of parking solutions but also the use of parking spaces over time. For example, the use of off-site parking facilities may be adapted depending on the long-term evolution of parking demand to serve different mobility needs such as car clubs, scooters, or bicycle storage;
- ii. Car parking design should be combined with landscaping to minimise the presence of vehicles;
- iii. Parking areas and driveways should be designed to minimise water run off through the use of permeable paving;
- iv. For small dwelling clusters, a front or rear parking court is acceptable. It is important to also introduce vegetation and appropriate boundary treatment to soften the presence of cars. For family homes, cars may be placed at the front or side of the property, the latter being preferred;
- v. When placing parking at the front, the area should be designed to minimise visual impact and to blend with the existing streetscape and materials. The aim is to keep a sense of enclosure and to break the potential of a continuous area of car parking in front of the dwellings by means of walls, hedging, planting, and use of differentiated quality paving materials.

On-plot front or side car parking

Some design guidelines for on-plot front and side car parking are:

- i. Sufficient and accessible off-road car parking must be provided on site or in the nearby vicinity to cater for the use proposed;
- ii. Parking on development sites should be well integrated so as not to dominate the public realm and must adhere to Local Plan adopted parking standard or guidelines;

- iii. High-quality and well-designed soft landscaping should be used to increase the visual attractiveness of the parking. Boundary treatments such as hedges, trees, flowerbeds and low walls also increase attractiveness and provide a clear distinction between public and private space; and
- iv. Hard standing and driveways must be constructed from porous materials to minimise surface water run-off.

- 1** Front parking with part of the surface reserved for soft landscaping. Permeable pavement to be used whenever possible.
- 2** Side parking set back from the main building line. Permeable pavement to be used whenever possible.
- 3** Boundary hedges to screen vehicles and parking spaces.

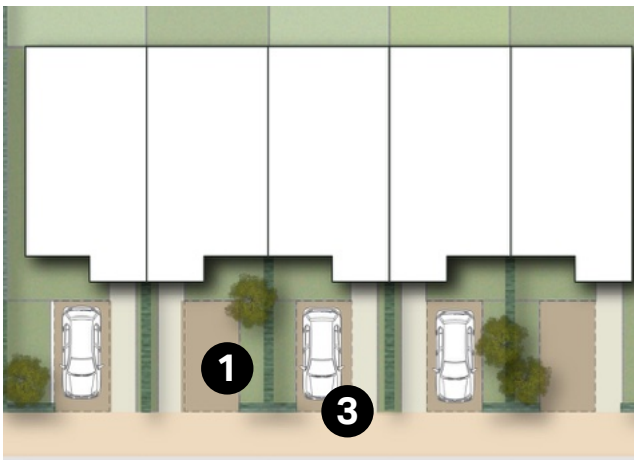

Diagram showing indicative layout for on-plot front parking.

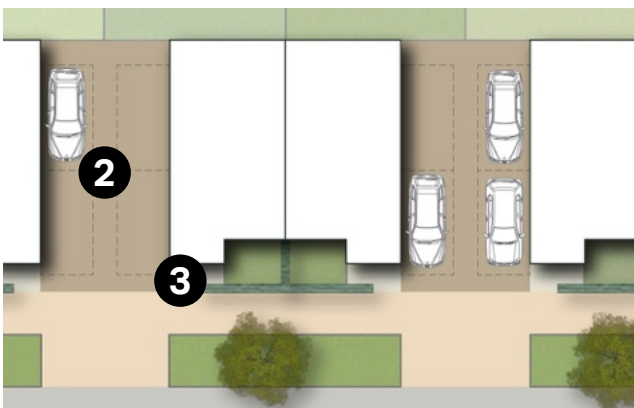

Diagram showing indicative layout for on-plot side parking.

Figure 23: On-plot car parking layouts.



Figure 24: Local example of on-plot front parking typology.



Figure 25: Local example of on-plot front parking typology.

On-plot garage

Where provided, garages must be designed either as free-standing structures or as additive form to the main building to ensure continuity of the buildingline. Some design guidelines are:

- i. Garages must complement and harmonise with the architectural style of the main building rather than forming a mismatched unit. They must also not result in excessively small and overshadowed gardens;
- ii. Garages need to be large enough to accommodate a modern, family sized car and some storage. Based on New Forest draft Parking Standards Supplementary Planning Document (2021), garages will be counted as car parking spaces where they have a minimum internal dimension 3.0m x 6.0m. This dimension prevents turning the garages into habitable or merely storage spaces; and
- iii. On-plot parking can be located either to the front or the side of the building and can be a covered car port or open.



Figure 26: Local example of on-plot garage typology.

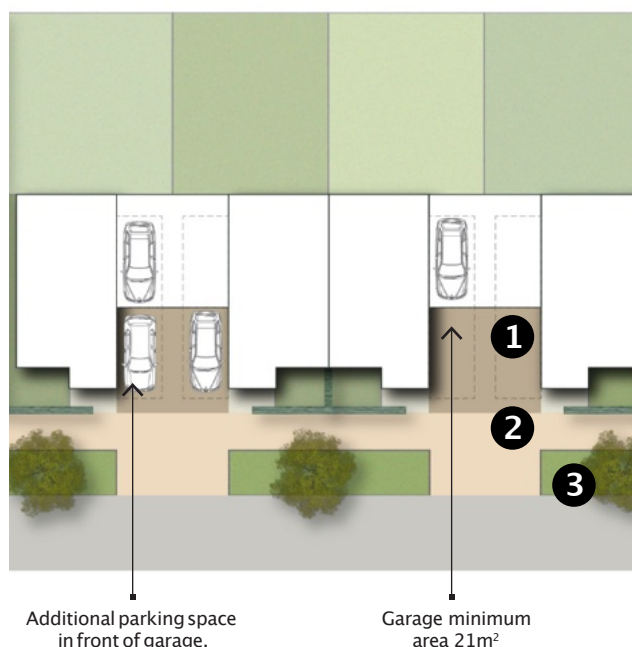

- 1 -Side parking set back from the main building line. Permeable pavement to be used whenever possible.
- 2 -Garage structure set back from main building line. Height to be no higher than the ground floor heights.
- 3 -Boundary hedges to screen vehicles and parking spaces.

Figure 27: On-plot garage layout. (left) Illustrative diagram showing an indicative layout of on-plot parking with garages. (right) Indicative layout of a garage with cycle storage area.

Bicycle parking and storage

The use of alternative modes of transport such as walking and cycling should be encouraged and supported with appropriate facilities. Therefore, all new developments should provide a safe and convenient cycle storage/parking in new homes and employment sites. Some design guidelines for new development are:

- i. Cycle storage must be provided at a convenient location with easy access;
- ii. The storage space must be designed for flexible use and should be well integrated into the streetscape if it is allocated at the front of the house;
- iii. New residential developments must provide secured covered cycle parking and publicly available cycle parking in the public realm;
- iv. The use of planting and smaller trees alongside cycle parking can be used to mitigate any visual impact on adjacent spaces or buildings;
- v. Visitor cycle parking within residential areas must be provided close to the buildings in the form of a suitable stand or wall bar; and
- vi. Bicycle stands in the public realm should be sited in locations that are convenient and that benefit from adequate natural surveillance. They should be placed in locations that do not impede pedestrian mobility or kerbside activities.



Figure 28: Example of enclosed cycle storage.



Figure 29: Example of a communal cycle parking in a residential scheme, UK.



Figure 30: Example of a communal cycle parking in a residential scheme, UK.

DC.02.3 Legibility and wayfinding

A legible and well signposted place is easier for people to understand as they can better orient themselves using landmarks and visual clues in the townscape. Being able to understand how a place fits together and knowing how to negotiate your way through it more easily makes for a more pleasant experience, as well as helping people to feel safer and more connected with their environment.

There are already a number of elements within the town that help people to locate themselves, including landmark buildings, specimen trees and smaller elements such as signs or unique bits of street furniture. Where these features exist, they should be protected; while new development should seek to use the same mix of elements to create clear visual links and establish a clear hierarchy and relationship between different spaces. Some design guidelines for new development are:

- i. Wayfinding must be clearly established throughout the town and should be designed to complement and not clutter the public realm;



Figure 31: The St Peter & St Pauls Parish Church is a building of historic importance and acts as a landmark for pedestrians and drivers.

- ii. New development should be designed and laid out in a manner that facilitates intuitive orientation and navigation, through appropriate uses of vistas and memorable features;
- iii. A familiar and recognisable environment makes it easier for people to find their way around. Obvious and unambiguous features should be designed in new development;
- iv. Buildings which are located at corners, crossroads or along a main road could play a significant role in navigation;
- v. At a local level, landmark elements could be a distinctive house, public art, or even an old and sizeable tree;
- vi. Elements like new signage design should be easy to read. Languages, fonts, text sizes, colours and symbols should be clear and concise, and avoid confusion;
- vii. Signage can promote existing and newly proposed footpaths and cycle lanes, encouraging people to use them more;
- viii. Signage should be strategically located to highlight gateways and access points, creating connections with important places and destinations; and
- ix. Signage elements and techniques should be appropriate to the character of the area and to the existing architectural style and details.

DC.03 Relationship with the street and other spaces

DC.03.1 Overlooking public space

Designing out crime and designing in community safety is essential to the creation of successful, safe and attractive developments.

The following guidelines are in line with the latest manual endorsed by the police 'Secured by Design Homes 2019'. The guidelines for new development are:

- i. There should be well-defined routes, spaces and entrances that provide convenient movement without compromising security;

- ii. Main building façades should overlook the open spaces to improve natural surveillance. In addition, side windows and driveways should also be well-overlooked;
- iii. Integrate facilities into the open spaces that meet the needs of the people living close by in order to make them attractive;
- iv. Avoid using too much green screening on the front gardens in order to allow for some views to the street and the open spaces; and
- v. Integrate light installations along the streets as well as in the open spaces in order to improve the feeling of safety in the area.

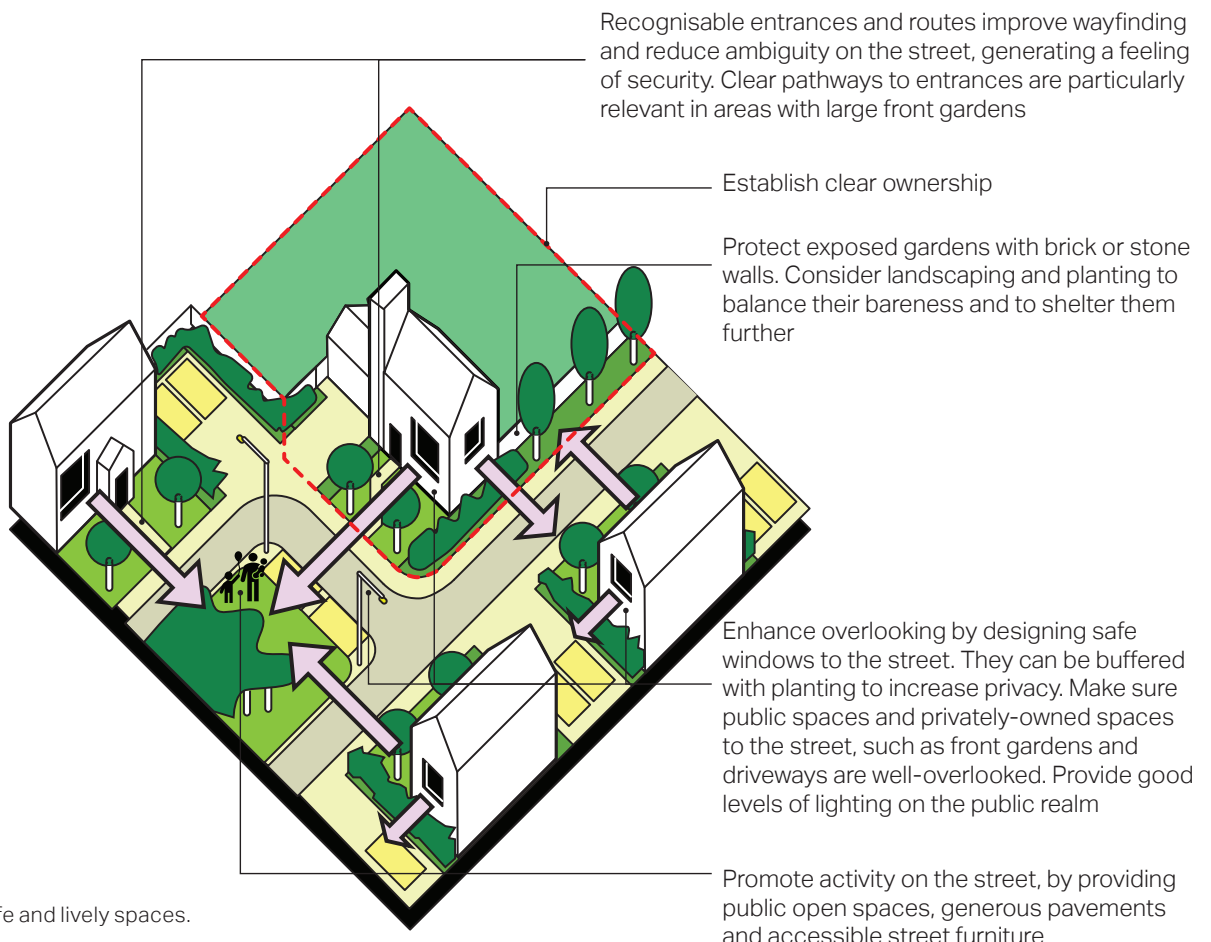

Figure 32: Safe and lively spaces.

DC.03.2 People-friendly streets

- i. Streets must meet the technical highways requirements as well as being considered a 'place' to be used by all, not just motor vehicles. It is essential that the design of new development should include streets and junctions that incorporate the needs of pedestrians, cyclists, and if applicable, public transport users. It is also important that on-street parking, where introduced, does not impede the access of pedestrians and other vehicles;
- ii. Within the settlement boundaries, streets should not be built to maximise vehicle speed or capacity. Streets and junctions must be designed with the safety and accessibility of vulnerable groups such as children and wheelchair users in mind, and may introduce a range of traffic calming measures;
- iii. New streets should generally be linear with gentle meandering, providing interest and evolving views while helping with orientation;
- iv. Streets must incorporate opportunities for landscaping, green infrastructure, and sustainable drainage;
- v. Where appropriate, cycle paths should be incorporated into street design to encourage people to use alternative transport;
- vi. Crossing points that are safe, convenient, and accessible for pedestrians of all abilities must be placed at frequent intervals on pedestrian desire lines and at key nodes;
- vii. Along low-traffic lanes and residential streets, crossing points can be more informal. For example, pedestrians may cross at any section of a street whose surface is shared between different users;
- viii. New homes must be within 20 minutes walk of existing or proposed conveniences (shops);
- ix. Junctions must enable good visibility between vehicles and pedestrians. For this purpose, street furniture, planting, and parked cars must be kept away from visibility splays to avoid obstructing sight lines; and
- x. Sufficient width of footway should be provided to facilitate a variety of mobilities, such as young families with buggies, mobility scooters, wheelchairs, etc. The Department for Transport Manual for Streets (2007) states there is no maximum width for a footway, it suggests that in lightly used streets, the minimum unobstructed width for pedestrians should generally be 2 m.

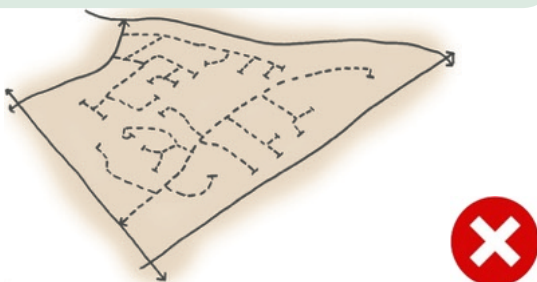

Figure 33: A layout dominated by cul-de-sacs encourages reliance on the car for even local journeys.

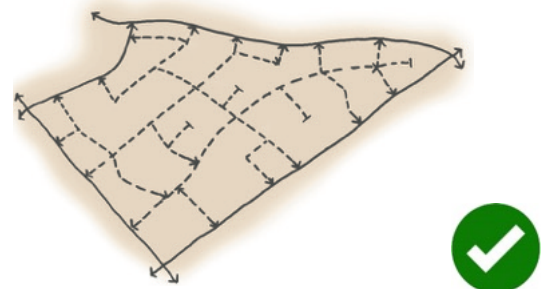

Figure 34: A connected layout, with some cul-de-sacs, balances sustainability and security aims in a walkable neighbourhood.

DC.03.2 Street planting

New street planting helps maintain visual consistency along the public realm. It is associated with better mental health and well-being by reducing stress and providing protection from natural elements such as wind and rain. Some guidelines for new development are:

- i. Flower beds, bushes and shrubs should be welcomed in new developments, since they contribute to the liveliness of the streetscape. Normally planted within the curtilage boundary, ornamental species add interest and colour to their surroundings and become an identity and expressive feature of each dwelling;
- ii. Hedgerows can be planted in front of bare boundary walls to ease their visual presence or they can be used to conceal on-plot car parking and driveways within curtilages;
- iii. Trees can normally be used to mark reference points and as feature

elements in the streetscape. When planted in intersections and key locations they can help with privacy whilst enhancing the wayfinding and distinctiveness of the area. These tend to be within property curtilages;

- iv. Trees should also be present in any public open space, green or play area to generate environmental and wildlife benefits;
- v. Retained trees should be considered at the earliest design stage to ensure that any retained trees will be able to grow and mature in the future without outgrowing their surroundings; and
- vi. The success of tree planting is more likely to be achieved when it has been carefully planned to work in conjunction with all parts of the new development, parking, buildings, street lights etc.



Figure 35: Local examples of street planting and vegetation.

DC.03.3 Street lighting

For maximum benefit, the best use of artificial light is about getting the right light, in the right place and providing light at the right time. Lighting schemes can be costly and difficult to change, so getting the design right and setting appropriate conditions at the design stage is important. Some guidelines for new development are:

- i. New development shall avoid the use of lighting, (e.g blue LED light) that has a negative impact on health and wellbeing. In addition, the use of coloured red and green lights should be diminished to mitigate any negative impact on safe navigation;
- ii. New development must consider lighting schemes that could be turned off when not needed. This could help mitigate any unacceptable levels of light pollution;
- iii. The needs of particular individuals or groups should be considered where appropriate (e.g. the safety of

pedestrians, cyclists, drivers or older people); and

- iv. Vegetation and planting on front gardens should be dense to absorb light and also offer some separation between public and private space.



Figure 36: Local examples of street lighting with appropriate distance from the dwellings in order to avoid causing disturbance to the residents and light pollution.

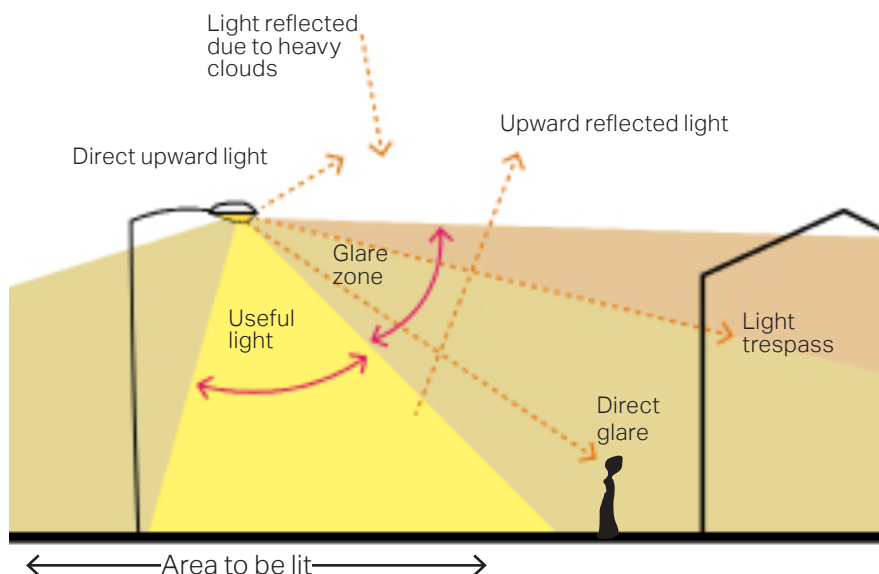

Figure 37: Diagram to illustrate the different components of light pollution and what 'good' lighting means.

DC.03.4 Enclosure

Focal points and public spaces in new development should be designed in good proportions and delineated with clarity. Clearly defined spaces help create an appropriate sense of enclosure - the relationship between a given space (lane, street, square) and the vertical boundary elements at its edges (buildings, walls, trees). The following principles serve as general guidelines that should be considered for achieving a satisfactory sense of enclosure in future development:

- i. When designing building setbacks, there must be an appropriate ratio between the width of the street and the height of the buildings;

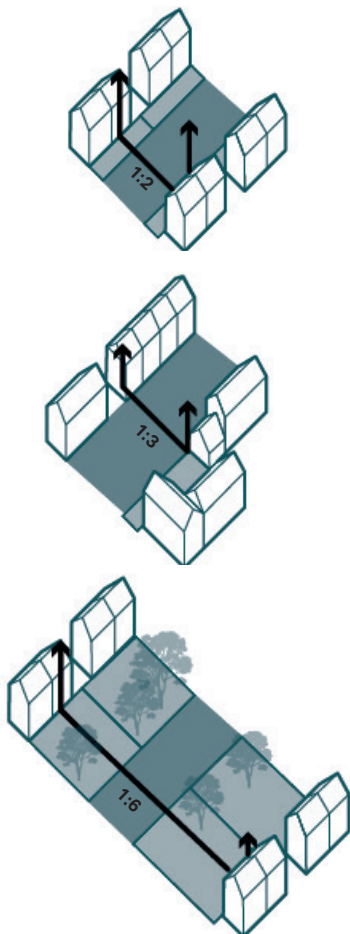

Figure 38: The various enclosure ratio depends on the amount of front garden width, road width, tree canopies and building heights.

- ii. Buildings should be designed to turn corners and create attractive start and end points of a new street or frontage;
- iii. Generally, building façades should front onto streets. Variation to the building line can be introduced to create an informal character;
- iv. In the case of terraced and adjoining buildings, it is strongly recommended that a variety of plot widths, land use, building heights, and façade depth should be considered during the design process to create an attractive streetscape and break the monotony of the street wall; and
- v. Trees, hedges, and other landscaping features can help create a more enclosed streetscape in addition to providing shading and protection from heat, wind, and rain.



Figure 39: Rich vegetation and large street trees can have an impact on the sense of enclosure on the streetscene.



Figure 40: Narrow streets and alleyways combined with terraced housing with limited gaps between buildings can create a sense of enclosure (1:2).

DC.03.5 Corner treatment

An important townscape principle is for buildings to satisfactorily address the corner. Where corner sites are visually prominent, buildings should define the corner architecturally. Some guidelines for future development are:

- i. Buildings should have multiple entrances if possible and two active frontages should be created by incorporating prominent entrances and windows;
- ii. On corners which are less visually prominent, such as within the lower

density residential areas, continuous built frontage should address the corner by using a series of linked dwellings where possible; and

- iii. When a terraced, detached or semi-detached house faces out onto the corner, the buildings should have the main entrance and habitable room windows facing both sides to create activity, and should overlook the street. This building can also be taller or have a distinctive architectural element to ensure a greater presence.

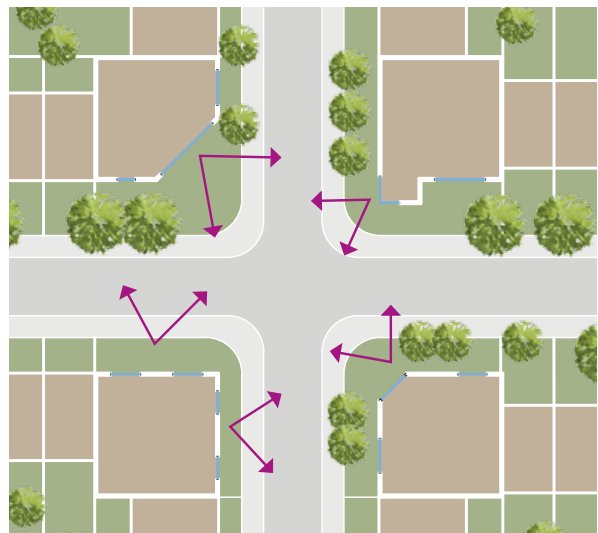

Figure 41: Diagram reflecting design principles for corner buildings.



Figure 42: Examples of corner buildings within the town with both facades active maximising natural surveillance and sun light.

DC.04 Development affecting heritage assets

There are several elements of historic significance in Ringwood which make a positive contribution to the character of the area. In particular, the grade II and II* listed buildings, mainly located within the conservation area, which include historic landmarks like The Meeting House, Clark's Almshouses, the Old Railway Station and 18-20 Market Place. Therefore, design guidelines should be in place to guide development in close proximity to heritage assets. Those guidelines are:

- i. Development which affects any designated and non-designated heritage asset must respect the significance of the asset and must demonstrate how local distinctiveness is reinforced;
- ii. Development should respect the significance of any designated and non-designated heritage assets. Particular consideration shall be given to maintaining their role in framing, punctuating or terminating key views through, out of and into the Town; and
- iii. Particular consideration shall be given to the retention of open spaces and gaps between buildings to sustain the historic form and pattern of development and the setting of heritage assets.



Figure 43: Church of St Peter and St Paul, Ringwood.



Figure 44: The Meeting House in Ringwood.

DC.05 Building scale and form

DC.05.1 Scale, form and massing

The scale, form and massing of buildings are important to the character of a place; therefore, the existing context needs to be considered and new development needs to react sensitively to preserve and enhance the best characteristics of a place ensuring a harmonious relationship with neighbouring buildings, spaces and streets. Across the town, the majority of the buildings are between two to three storeys, down to single storey for cottages and bungalows. Some guidelines for future development are:

- i. Development within the town should be of a scale and design to reinforce the locally distinctive character of the area;
- ii. The scale and massing of new buildings should be in keeping with the form and massing of neighbouring properties and must have regard of their impact at street level and also to their appearance from more distant views; and
- iii. The height of new buildings should be in keeping with neighbouring properties and the design shall demonstrate how heights of development will not be over-bearing or dominant in the existing street scene and on the overall townscape.



Figure 45: Building heights and massing have subtle variations and are generally in keeping with neighbouring properties.

DC.05.2 Building lines and boundary treatments

Building line and boundary treatments vary across the town. To respect the existing context, both the building and the boundary features should be consistent with neighbouring properties while enabling enough variations for visual interest. Some design guidelines for future development are:

- i. Buildings should front onto streets. The building line should have subtle variations in the form of recesses and protrusions but should generally form a unified whole;
- ii. Buildings should be designed to ensure that streets and/or public spaces have good levels of natural surveillance from buildings. This can be ensured by placing ground floor

habitable rooms and upper floor windows facing the street;

- iii. Natural boundary treatments should reinforce the sense of continuity of the building line and help define the street, appropriate to the character of the area. They should be mainly continuous hedges and low walls, as appropriate, made of traditional materials found elsewhere in the town such as local bricks. The use of either panel fencing or metal or concrete walls in these publicly visible boundaries should be avoided. Natural boundary treatments should still enable adequate natural surveillance; and
- iv. In the case of edge lanes, natural boundary treatments can act as buffer zones between the site and the countryside and offer a level of protection to the natural environment.



Figure 46: Examples of different types of boundary treatments and boundary lines within the town. A subtle variation in the vegetation and building lines creates a visual interest and offers aesthetic variety in the streetscape.

DC.05.3 Infill development and housing extensions

Infill development

There are several examples, both positive and negative, of infill development within the town. Therefore, some design guidelines for infill development would be useful to provide a design context that respects the adjacent properties and the local vernacular of the area.

- i. Infill development should complement the street scene into which it will be inserted. It needs to reflect the materials, scale, massing and layout of the surrounding properties, as shown in Figure 47;
- ii. The above elements also need to be considered in relation to topography, views, vistas and landmarks;

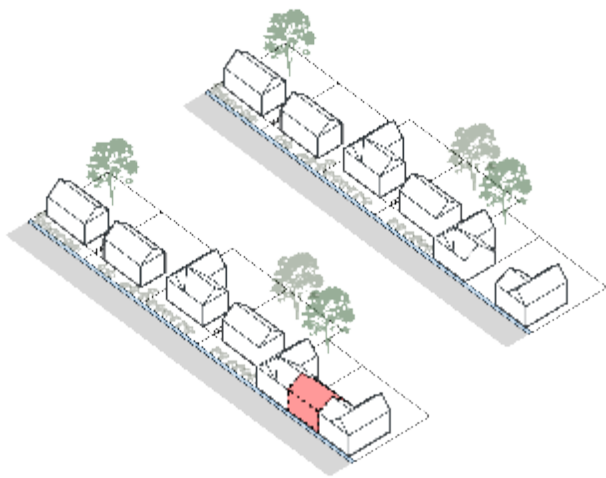

Figure 47: Indicative diagrams illustrating a site before and after infill.

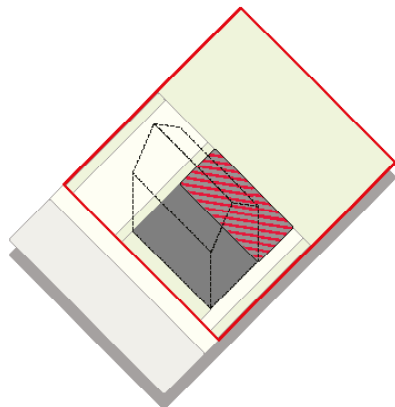

Figure 48: Diagram illustrating the basic principle about 50% coverage of the plot area for both the main building and annex.

- iii. New building lines should be reasonably consistent along a street with existing buildings;

Plot coverage

There is a trend in the town for small outbuildings to be erected in gardens, often for holiday accommodation. This can bring issues of amenity and also affect drainage and biodiversity. Plot area ratios can be used to inform appropriate development massing. Plot area ratio is the proportion of the site area occupied by buildings, calculated by dividing the gross ground floor area of the building by the plot area.

- iv. Residential development here should accord with existing precedent which is generally <0.5 . Higher densities may be appropriate in some areas owing to existing precedent, as shown in Figure 48 ;

Housing extensions

Extensions to dwellings can have a significant impact not only on the character and appearance of the building, but also on the street scene within which it sits. A well-designed extension can enhance the appearance of its street, whereas an unsympathetic extension can create problems for neighbouring residents and affect the overall character of the area. The Planning Portal¹ contains more detailed information on building modifications and extensions, setting out what is usually permitted without planning permission (permitted development) as well as what requires planning permission. Some guidelines for new development are:

- v. Extensions must be appropriate to the scale, massing and design of the main building and its adjacent buildings, and should complement the streetscape;
- vi. Alterations and extensions of historic buildings within a conservation area

1. Planning Portal. https://www.planningportal.co.uk/info/200234/home_improvement_projects

should preserve or enhance their character;

- vii. Extensions are more likely to be successful if they do not exceed the height of the original or adjacent buildings. Two-storey extensions, where appropriate, should be constructed with a pitch sympathetic to that of the existing roof;
- viii. The design, materials and architectural detailing of extensions should be high-quality and respond to the host building and the local character of the town;
- ix. The impact on the space around the building should avoid overlooking, overshadowing or overbearing. In particular, overusing the plot size should be avoided;

Side extension

Side extension is one popular way to extend a building to create extra living space. However, one effect is to reduce the number of smaller and therefore, cheaper houses in the town thus reducing affordability. Some design guidelines on side extensions are:

- x. Side extensions should not detract from the appearance of the building, its surroundings and the wider townscape;
- xi. Single-storey and double storey side extensions should be set back from the main building and complement the materials and detailing of the original building;
- xii. The roof of the extension should harmonise with that of the original building; flat roofs should be avoided;
- xiii. Side windows should also be avoided unless it can be demonstrated that they would not result in overlooking of neighbouring properties;

Rear extension

Single storey rear extension is generally the easiest way to extend a house and provide extra living space. Some design guidelines on rear extensions are:

- xiv. The extension should be set below any first-floor windows and designed to minimise any effects of neighbouring properties, such as blocking day light.;
- xv. A flat roof is generally acceptable for a single storey rear extension; and
- xvi. Double storey rear extensions are not common as they usually affect neighbours' access to light and privacy, however, sometimes the size and style of the property allows for a two-storey extension. In these cases, the roof form and pitch should reflect the original building and sit slightly lower than the main ridge of the building.

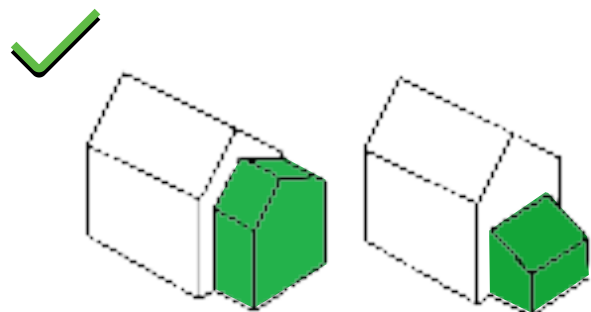

Good examples for side extensions, respecting existing building scale, massing and building line.

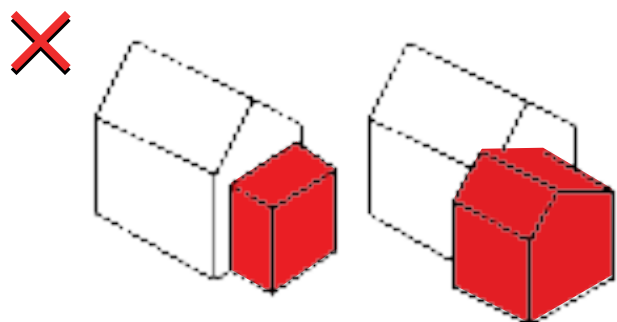

Both extensions present a negative approach when considering how it fits to the existing buildings. Major issues regarding roofline and building line.

DC.05.4 Density

Housing density is measured by the number of dwellings per hectare. The concept of density is important to planning and design as it affects the vitality and viability of the place. There is a variety of housing densities within Ringwood town ranging from high, within the town centre, to lower, when it gets closer to the open fields.

Therefore, some guidelines for new development are needed to ensure that the existing housing density numbers are respected.

- i. Density should be appropriate to the location of any new development and its surroundings and enhance the character of the existing settlement;
- ii. For larger development proposals a subtle range of densities should be proposed to allow for variety in building types and forms. This creates a visual interest as well as meeting the needs of a wider group of people;
- iii. Higher densities could be proposed around key movement intersections and along strategic routes to signalise their importance and improve legibility. In addition, higher densities can support the viability of local services and facilities;
- iv. Pedestrian movement should be a priority and taken into account in larger development schemes. Housing density should support a 'human scale' development;
- v. In the case of perimeter blocks, which are highly encouraged, their size should be large enough to fit adequate amenity space and parking, yet small enough to allow a permeable and walkable patterns;
- vi. Housing densities should be reduced towards settlement edges and along rural edges in order to create a

gradual transition between town and countryside.

- vii. Small scale development and in-fills are encouraged, because they follow the scale and pattern of existing grain and streets and therefore, retain the character of the area.



Figure 49: The town centre is characterised by higher housing density in comparison to other locations in the town, Ringwood.



Figure 50: Example of a lower housing density within the town.

DC.05.5 Building conversions

Retention and reuse of existing buildings is a sustainable option, in that it retains embodied energy/carbon and minimises the use of new resources.

The conversion or adaptation of existing vacant or redundant buildings is encouraged, particularly where they make a significant contribution to the wider townscape and the character of the area. Some guidelines are:

- i. Proposals for the conversion of existing property should be sympathetic to the building and propose an appropriate reuse/adaptation of the asset;
- ii. The architectural character and scale of the building should be carefully considered, and traditional materials and simple detailing employed when converting existing buildings;

- iii. Existing window and door openings should be retained and reused, and the number of new openings kept to a minimum. This is particularly important in the case of farm buildings to ensure that their agricultural character is retained;
- iv. Proposals that imitate historic architectural styles, using cheaper modern materials and demonstrating a lack of attention to detail as to the character and form of historic buildings within the settlement (including matters such as materials, proportion, massing, fenestration, rooflines/detailing, etc.), will be resisted; and
- v. Conversion of existing garages must not result in a reduction in existing on-site parking.



Figure 51: Positive examples of building conversions within the town that are sensitive to the surrounding context.

DC.05.6 Roofline

Creating a good variety in the roof line is a significant element of designing attractive places. There are certain elements that serve as guidelines in achieving a good variety of roofs:

- i. Roofline should be well articulated and in proportion with the dimensions of the building with subtle changes in the roofline to avoid monotonous elevations and avoid bulky, featureless appearance;
- ii. The scale of the roof should always be in proportion with the dimensions of the building itself;

- iii. Monotonous repetitions of the same building elevations should be avoided, therefore subtle changes in roofline should be ensured during the design process;
- iv. Traditional local roof materials, shapes, and detailing should be considered and implemented where possible in cases of new development; and
- v. Dormers can be used as a design element to add variety and interest to roofs. They should be proportional to the dimensions of the roof and façade, and their design should be coordinated with the materials and architectural style used on the rest of the elevation.



Figure 52: The average building height within the town is between 2-3 storeys. The subtle variation in the eaves and ridge levels create a harmonious roofline that is well integrated with the vegetation and countryside in the background.

DC.06 Architectural styles, materials and details

DC.06.1 Architectural style

Ringwood has a rich vernacular architecture which constitutes its distinctive character and identity. There is a rich heritage of historic buildings, both of residential and industrial use, with various architectural styles such as cottages, Victorian villas and Georgian town houses. Terraced housing is a distinct characteristic of the historic town centre which allows for continuous façades along the narrow streets.

The photos presented on the next pages are a showcase of architectural styles, details and materials found in the town. In general some design guidelines for new development are:

- i. New development should use materials and architectural detailing that contributes to the historic and vernacular character of the area. It is important that the materials used in proposed development are of a high quality and reinforce local distinctiveness;
- ii. New development should demonstrate that the palette of materials has been selected based on a solid knowledge of the local vernacular style and traditions;
- iii. New development should reflect an intelligent understanding of the building details of the historic settlement cores without resulting in low-quality imitations of past styles; and
- iv. Any affordable housing development should be of high-quality and be indistinguishable from other houses.



Figure 53: The Old Bank House, is a building of great historic significance faced with yellow mathematical tiles, which are tiles fitted together to look like bricks.



Figure 54: The Old Cottage Restaurant is a Grade II Listed Building, with timber-frame with painted brick and thatch roof.



Figure 55: Rear view of 2 Market Place which is unsympathetically extended and repurposed, neglecting its historical value

DC.06.2 Materials and colour palette

There is a range of architectural styles used within the town for walls, roofscape and fenestration.

The predominant building material used in the town is red brick with some examples of grey and local yellow brick, flint and coloured rendering. There are a mixture of brick and flint walls to be found across the town. Most roofs use Norfolk pantiles or slate tiles.

Some design guidelines for new development are:

- i. Architectural design shall reflect high quality local design references in both the natural and built environment and reflect and reinforce local distinctiveness; and
- ii. Any future development proposals should demonstrate that the palette of materials has been selected based on an understanding of the surrounding built environment.

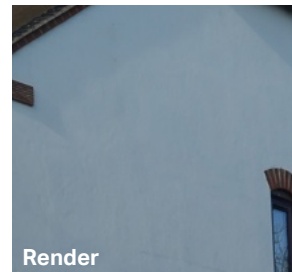
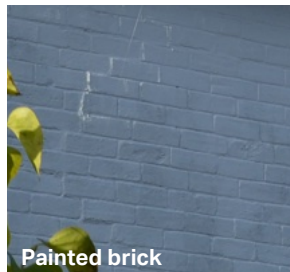
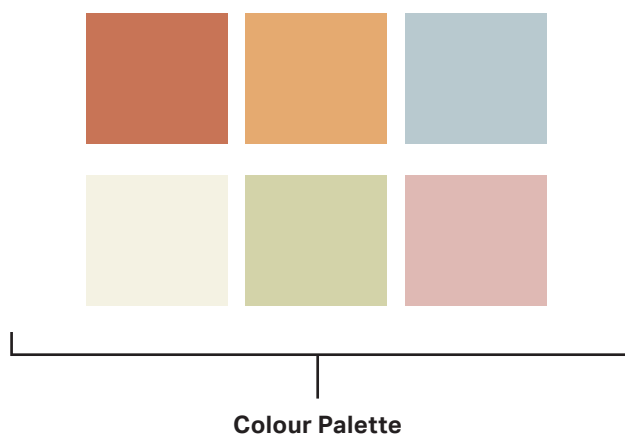

Figure 56: Positive local examples for wall materials in Ringwood.



Hipped roof with black pantiles



Gabled roof with red pantiles



Shed dormer



Plain clay tiles



Casement window with some yellow brickwork around



Sash window with rendered wall



Bay window on a red brick wall



Sash window with brickwork



Thatch roof



Painted bricks in different colours



Off-white painted brick



Decorated flat Porch



Chimney stacks



Porch



Jerkinhead roof



Wall decorations and details

DC.06.3 Building proportion

The relationships between the building and its elements can provide visual interest and enhance the local character. Some guidelines for future development are:

- i. The proportions of a building's elements should be related to each other as well as the scale and proportion of the building;
- ii. The proportions should be dictated by and respond to the type of activity proposed as well as the composition of the existing streetscape;
- iii. The front elevation of the buildings must be arranged in an orderly way to avoid creating cluttered facades; and
- iv. Features such as windows, doors and solid walls should create vertical and horizontal rhythms along the façade providing variety.



DC.06.4 Windows

The detailing, materials and fenestration of windows along building façades can inform the character of the street. Within the town, there are a variety of window styles with a predominance of casement and bay windows in older buildings that should be used as guidance for future windows in the town. Some guidelines for future development are:

- i. Windows should match the general orientation, proportion and alignment of other windows in the same building as well as those on adjacent properties, reinforcing the continuity of the streetscape;
- ii. Windows in new developments should have consistent colour, thickness of frame and quality

of windows across all elevations. Where PVC is used to replace other materials it should be of such character as to mimic the original design; and

- iii. Windows should employ a particular design approach by adopting either a contemporary or traditional style. Contemporary style buildings can have a variety of window designs whereas traditional building styles should have a limited range of patterns.



Figure 57: Examples of locally distinctive windows in the town.

DC.06.5 Doors

Different types of doors are used throughout the town creating an interesting and varied streetscape. Some guidelines for future development are:

- i. New development must use the existing architectural styles as inspiration in order for new doors to be in keeping with the town streetscape; and
- ii. Small porches and canopies at the entrance of buildings should be in keeping with the style and size of the house and should respect the building line of the street, particularly where a strongly defined building line is an important characteristic of a street. The roof pitch should match that of the original building to ensure it blends in with the building.

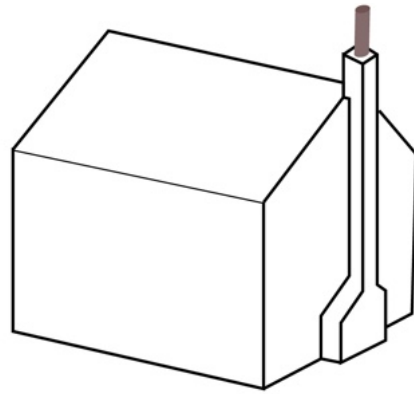

Figure 58: Examples of locally distinctive doors in the town.

DC.06.6 Chimneys

Chimneys can be seen across the town in all housing types, therefore, they can be placed in several locations. A modern approach should be taken to chimney design and chimneys should only be incorporated where they serve a function. In the case of small dwellings without fireplaces, gas fuel or soil and vent outlets can be combined into chimney structures. Some guidelines for future development are:

- i. Chimneys must match the primary elevation material and be placed symmetrically to the ridge line; and
- ii. Chimneys shall rise above the roof and when on an end elevation should connect to the ground. Chimneys should be positioned on the ridge of the roofs, centrally on a gable end or against an out-scale wall and should have pots.



Chimney connecting to the ground

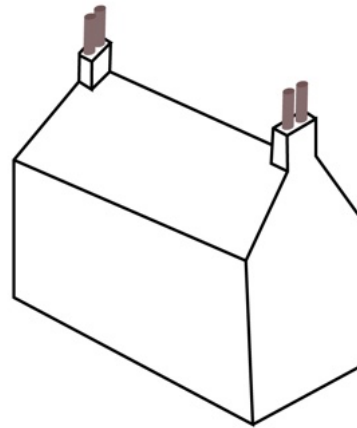

Symmetrical chimneys-directional emphasise suitable harmonious effect.

Figure 59: Examples of chimneys.



Figure 60: Examples of locally distinctive chimneys in the town. Some chimneys are integral to the building mass, while others sit outside and form projection.

DC.07 Open space

DC.07.1 Open space

There is a wide range of open spaces within the fabric of Ringwood including Carvers recreation ground, large, popular, park located in the heart of Ringwood in Southampton Road.

However, the presence of open space within and around an area can have a positive impact. If this is combined with mature trees, hedges and the surrounding landscape, then it contributes significantly to the improvement of the quality of the street scene. Therefore, some guidelines are:

- i. Open space should have a purpose and be of a size, location and form appropriate to the intended use, avoiding space left over after planning or pushing open space to the periphery of development;
- ii. Open spaces should be located within walking distance from their intended users, and if possible linked to form connected green networks. Where direct links are not possible, open spaces should be linked through green routes, shared surface and tree lined streets;
- iii. Public open spaces should be overlooked by surrounding buildings to promote natural surveillance and social gatherings. This could be achieved by placing them at the centre of the neighbourhood or part of the neighbourhood;
- iv. New open spaces should not be used as a divisive measure between new and existing development, even though green buffer zones which distinguish between older and new development are acceptable;
- v. Open spaces should offer choices for the needs and desires of users of all ages and abilities. These include active sports, play spaces, communal gardens and quiet spaces. Play spaces should be accessible to all children and their design must consider seating areas for carers, shaded spaces and no hidden spots; and
- vi. Play areas should include elements relating to nature and landscape and the equipment and fittings employed should be of high quality, durability and conforming to the relevant standard.



Figure 61: Carvers recreation ground includes a cricket pitch and pavilion, a bowling club and green, as well as a play area and a Skate Park.

DC.07.2 Biodiversity and wildlife

Ringwood has a rich and varied landscape character. There are many natural features and assets, such as trees, hedges, front and back gardens, open spaces, recreational grounds, marshes, farmland. They all contribute to provide habitats for biodiversity to flourish. Therefore, any new development or any change to the built environment should:

- i. Seek to protect existing habitats and strengthen the biodiversity of the natural environment. In particular, development should enhance existing wildlife corridors that form the links between the urban and hinterland landscapes;
- ii. Preserve and protect the local wildlife and seek the creation of green corridors to benefit biodiversity;

- iii. Protect and enhance hedges, trees and road verges, where possible;
- iv. Avoid abrupt edges to development with little vegetation or landscape on the edge of the settlement and, instead, aim for a comprehensive landscape buffering; and
- v. Employ boundary treatments to the side and rear of the property, which are permeable to wildlife. For example, native hedgerow, gapped wooden palisade or 'hit and miss' fencing with wildlife friendly gravel boards should be considered.



Figure 62: A swift brick



Figure 63: Example of a bug habitat decorating rear gardens or public green spaces

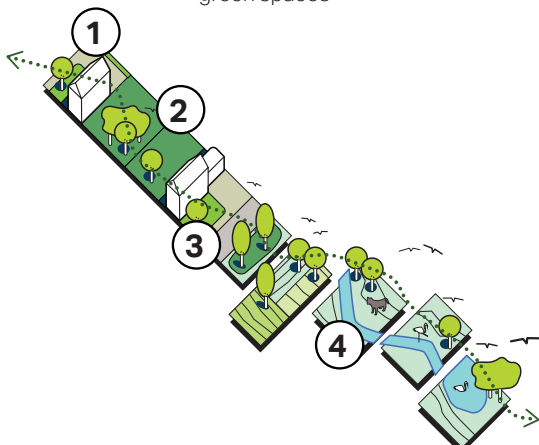

Figure 64: Public green open spaces can help enhance the wildlife.



Figure 65: Front and back gardens can play an important role in enhancing the wildlife.



Figure 66: Countryside and farmland can help enhance the wildlife.

DC.08 Sustainable design

DC.08.1 Sustainable design

New developments should be designed for climate change mitigation and adaptation. Development proposals should consider layout, aspect, massing and use of materials in order to reduce energy consumption and thereby minimise contributions to climate change.

Historic buildings within the town can provide good examples of sustainable layouts and construction methods along with the efficient use of energy and local resources. Their survival reflects their success and adaptability.

There are opportunities in most historic buildings to improve energy conservation without causing harm, through measures such as secondary glazing, improved loft insulation using natural materials, low energy lighting and the use of fuel-efficient boilers. In some situations, renewable energy technologies can also be installed without causing harm to the heritage significance.

- i. The orientation of buildings within the plot, along with the site topography, must be considered to maximise solar gain while keeping a consistent frontage to the street;
- ii. Living spaces within each typology should be oriented according to the expected use of each room, e.g. sun in the morning for kitchens, during the day for living areas, and in the evening for bedrooms;
- iii. The design of new developments must maximise the use of energy efficiency and energy conservation fixtures, fittings and technology. Passive methods of heating and

cooling and the use of renewable energy technologies such as ground source and air source heat pumps, biomass heating, photovoltaics and solar panels must be considered for new developments. Opportunities for the use of the same technologies in existing buildings, when undergoing refurbishment, will also be expected;

- iv. Appropriate materials and detailing should be considered to minimise heat loss. Direct entry from the street to an interior living space should be avoided where possible; and
- v. Solar access along the south façade should be maximised and openings on the north one minimised. Appropriate shading elements and cross ventilation should be employed in new and existing buildings.

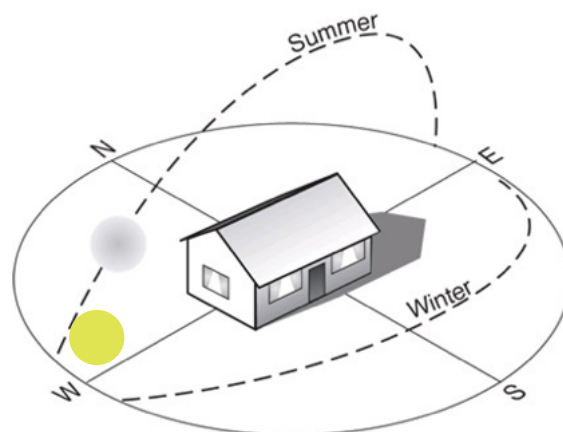

Figure 67: Illustration to show the appropriate building orientation so as to maximise solar gains. Windows should be placed mainly on the southern side whilst fewer openings should be located on the northern. A deep roof overhang can offer some shading. This can also be improved with some trees and vegetation around the house. (Source: <https://nextdayinspect.com/building-orientation-for-optimum-energy/>).

DC.08.2 Net-zero carbon

Energy efficient or eco design combines all-round energy efficient construction, appliances, and lighting with commercially available renewable energy systems, such as solar water heating and solar electricity.

Starting from the design stage, there are strategies that can be incorporated towards passive solar heating, cooling and energy efficient landscaping which are determined by local climate and site conditions. The retrofit of existing buildings with eco design solutions should also be encouraged.

The aim of these interventions is to reduce overall home energy use as cost effectively as the circumstances permit. The final step towards a high-performance building would consist of other on site measures towards renewable energy systems.

It must be noted that eco design principles do not prescribe a particular architectural style and can be adapted to fit a wide variety of built characters. A wide range of solutions is also available to retrofit existing buildings,

included listed properties, to improve their energy efficiency¹.



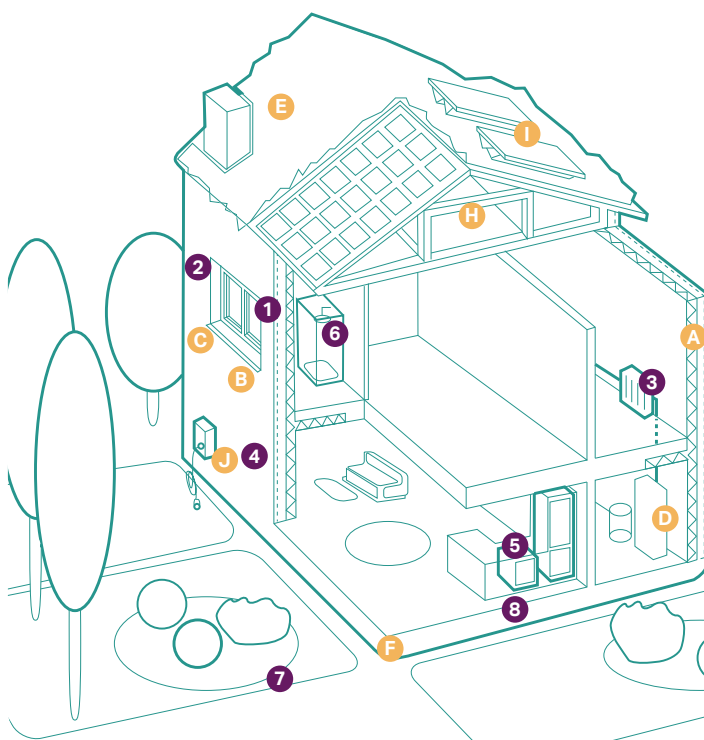





- i. Buildings must be built with high levels of energy efficiency. Construction materials should be effectively reused, recycled and locally sourced. Material should be transported on site in the most sustainable manner and have low embodied energy; and
- ii. Buildings must achieve at least a minimum level of carbon reductions through a combination of energy efficiency, on-site energy supply and/or (where relevant) directly connected low carbon or renewable heat and choose from a range of (mainly off-site) solutions for tackling the remaining emissions.



Existing homes

- 1  **Insulation**
in lofts and walls (cavity and solid)
- 2  **Double or triple glazing with shading** (e.g. tinted window film, blinds, curtains and trees outside)
- 3  **Low-carbon heating**
with heat pumps or connections to district heat network
- 4  **Draught proofing** of floors, walls, windows and doors
- 5  **Highly energy-efficient appliances** (e.g. A++ and A+++ rating)
- 6  **Highly waste-efficient devices** with low-flow showers and taps, insulated tanks and hot water thermostats
- 7  **Green space (e.g. gardens and trees)** to help reduce the risks and impacts of flooding and overheating
- 8  **Flood resilience and resistance** with removable air back covers, relocated appliances (e.g. installing washing machines upstairs), treated wooden floors

Additional measures in new build homes

- A  **High levels of airtightness**
- B  **More fresh air** with mechanical ventilation and heat recovery, and passive cooling
- C  **Triple glazed windows and external shading** especially on south and west faces
- D  **Low-carbon heating**
- E  **Water management and cooling** more ambitious water efficiency standards, green roofs and reflective walls
- F  **Flood resilience and resistance** e.g. raised electrical, concrete floors and greening your garden
- H  **Construction and site planning** timber frames, sustainable transport options (such as cycling)
- I  **Solar panels**
- J  **Electric car charging point**

1. Historic England. <https://historicengland.org.uk/advice/technical-advice/energy-efficiency-and-historic-buildings>,

DC.08.3 Solar roof panels

Solar panels (PV or hot water heating) can have a positive environmental impact. However, their design and installation needs careful consideration, particularly when carried out on historic buildings or within sensitive areas. Preservation of the character of the town is a priority, but there are numerous examples where technology has been designed to reflect and complement local vernacular and character.

A few principles relating to the sensitive installation of solar technology are set out below:

On new builds:

- i. Use the solar panels as a material in their own right;
- ii. Adopt solar technology from first principles, embedding their use into the design concept from the very start. Some attractive options are solar shingles and photovoltaic slates;

- iii. Analyse the proportions of the building and roof surface in order to identify the best location and sizing of panels;
- iv. Consider introducing other tile or slate colours to create a composition with the solar panel materials;
- v. Conversely, aim to introduce contrast and boldness with proportion. There has been increased interest in black panels due to their more attractive appearance. Black solar panels with black mounting systems and frames can be an appealing alternative to blue panels; and
- vi. Carefully consider the location of solar panels on buildings within the historic part of Ringwood town. It might be appropriate to introduce solar panels to areas of the building that are more concealed in order to preserve the character and appearance of the town.



Figure 68: Solar panels on the south-facing side of the roof of an existing house in Ringwood.

DC.08.4 Green roofs

Green roofs improve drainage, add to biodiversity and, in some instances, can improve the thermal performance of the roof.

- i. Whether the roof is partially or completely covered with vegetation, its design should follow some basic principles such as, having been planned from the design stage; being easy to reach and maintain; being complementary (where applicable) to its immediate environment and helping to integrate the building with the surrounding landscape; and
- ii. Design comprehensively with other eco designs such as water harvesting and porous pavements.



Figure 69: Green elements can be integral to the roofs of storage rooms in the garden. In this way, those structures become part of the landscape and their presence is less apparent. (Source: <https://www.lowimpact.org/lowimpact-topic/living-roofs/>).



Figure 70: Lightweight green roof on residence in Manchester, UK (Source: <https://www.sempergreen.com/en/references/private-residence-1>).

DC.08.5 Sustainable drainage systems

New developments should seek to reduce flood risk overall through creation of multi-functional green infrastructure and sustainable drainage systems. It is essential to demonstrate that the development will be safe and flood risk is not increased elsewhere.

It is important to change the traditional approach to managing flood risk to one of accepting water as a valuable resource whose benefits should be maximised within the design process.

New developments should consider the amenity and aesthetic value of surface water in the urban environment alongside long term environmental, biological and social factors in the context of climate change and urbanisation.

SuDS should be considered as a key design tool to achieve those wider goals and not a mere functional requirement.

- i. New and existing developments must capitalise on SuDS possibilities as a key design element to provide amenity and aesthetic value to the development.

SuDs definition

The term SuDS stands for Sustainable Drainage Systems. It covers a range of approaches to managing surface water in a more sustainable way to reduce flood risk and improve water quality whilst improving amenity benefits.

SuDS work by reducing the amount and rate at which surface water reaches the combined sewer system. Usually, the most sustainable option is collecting this water for reuse, for example, in a water butt or rainwater harvesting system, as this has the added benefit of reducing pressure on important water sources.



Figure 71: Examples of SuDS designed as a public amenity and fully integrated into the design of the public realm, Sweden.

Where reuse is not possible there are two alternative approaches using SuDS:

- Infiltration, which allows water to percolate into the ground and eventually restore groundwater; and
- Attenuation and controlled release, which holds back the water and slowly releases it into the sewer network. Although the overall volume entering the sewer system is the same, the peak flow is reduced. This reduces the risk of sewers overflowing.

The most effective type or design of SuDS would depend on site-specific conditions such as underlying ground conditions, infiltration rate, slope, or presence of ground contamination. A number of overarching principles can however be applied:

- ii. Manage surface water as close to where it originates as possible;
- iii. Reduce runoff rates by facilitating infiltration into the ground or by providing attenuation that stores water to help slow its flow down so that it does not overwhelm water courses or the sewer network;

- iv. Improve water quality by filtering pollutants to help avoid environmental contamination;
- v. Integrate into development and improve amenity through early consideration in the development process and good design practices;
- vi. SuDS are often as important in area that are not directly in an area of flood risk themselves, as they can help reduce downstream flood risk by storing water upstream; and
- vii. Some of the most effective SuDS are vegetated, using natural processes to slow and clean the water whilst increasing the biodiversity value of the area.

DC.08.7 Storage and slow release

Rainwater harvesting refers to the systems allowing capture and storage of rainwater as well as those enabling the reuse in-situ of grey water. Simple storage solutions, such as water butts, can help provide significant attenuation. To be able to continue to provide benefits, there has to be some headroom within the storage solution. If water is not reused, a slow release valve allows water from the storage to trickle out, recreating capacity for future rainfall events. New digital technologies that predict rainfall events can enable stored water to be released when the sewer has greatest capacity to accept it.

These systems involve pipes and storage devices that could be unsightly if added without an integral vision for design. Therefore, some design recommendation would be to:

- i. Conceal tanks by cladding them in complementary materials;
- ii. Use attractive materials or finishing for pipes;

- iii. Combine landscape/planters with water capture systems;
- iv. Install underground tanks; and
- v. Utilise water bodies for storage.

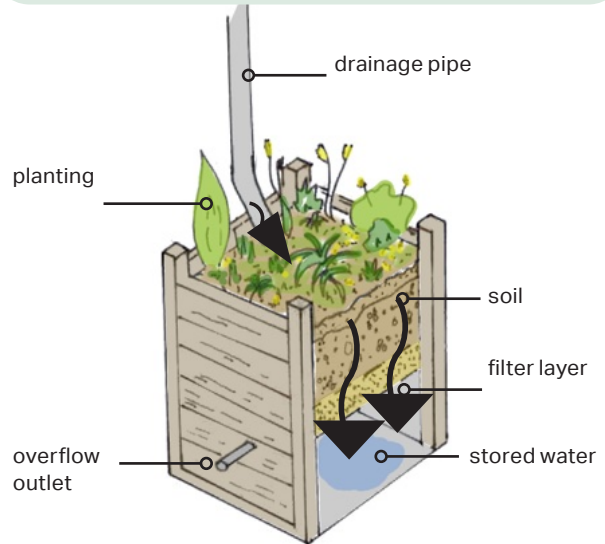

Figure 73: Diagram illustrating the functioning of a stormwater planter.

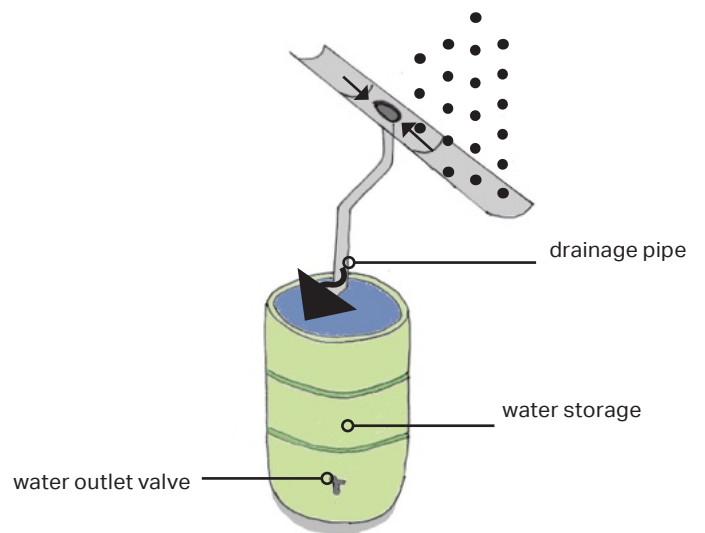

Figure 74: Diagram illustrating the functioning of a water butt.



Figure 72: Examples of water butts used for rainwater harvesting.

DC.08.8 Permeable paving

Most built-up areas, including roads and driveways, increase impervious surfaces and reduce the capacity of the ground to absorb runoff water. This in turn increases the risks of surface water flooding. Permeable pavings offer a solution to maintain soil permeability while performing the function of conventional paving. The choice of permeable paving units must be made depending on the local context; the units may take the form of unbound gravel, clay pavers, or stone setts.

Permeable paving should be used where possible on footpaths, public squares, private access roads, driveways, and private areas within development boundaries. In addition, permeable pavement must also align with the following Acts:

- Flood and Water Management Act 2010, Schedule 3¹;
- The Building Regulations Part H – Drainage and Waste Disposal²; and
- Town and Country Planning (General Permitted Development) (England) Order 2015³.



Figure 77: Examples of permeable paving that can be used in the front and rear gardens of residential buildings.

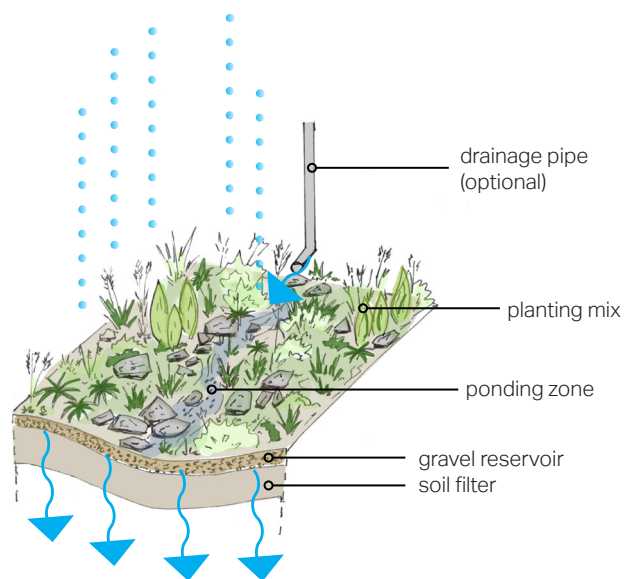

Figure 75: Diagram illustrating the functioning of a rain garden.

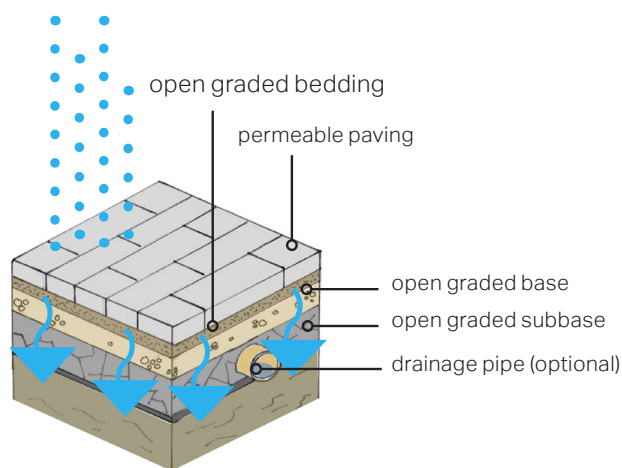

Figure 76: Diagram illustrating the functioning of a soak away.

1 Great Britain (2010). Flood and Water Management Act, Schedule 3. Available at: <http://www.legislation.gov.uk/ukpga/2010/29/schedule/3>

2 Great Britain (2010). The Building Regulations Part H – Drainage and Waste Disposal. Available at: https://assets.publishing.service.gov.uk/government/uploads/system/uploads/attachment_data/file/442889/BR_PDF_AD_H_2015.pdf

3 Great Britain (2015). Town and Country Planning (General Permitted Development) (England) Order 2015. Available at: http://www.legislation.gov.uk/uksi/2015/596/pdfs/uksi_20150596_en.pdf

4.3 Applying the design guidance to character areas

This sub-section provides more detailed guidance for three of the character areas identified in the Ringwood Local Distinctiveness SPD. It is to be applied alongside the guidance in that document.

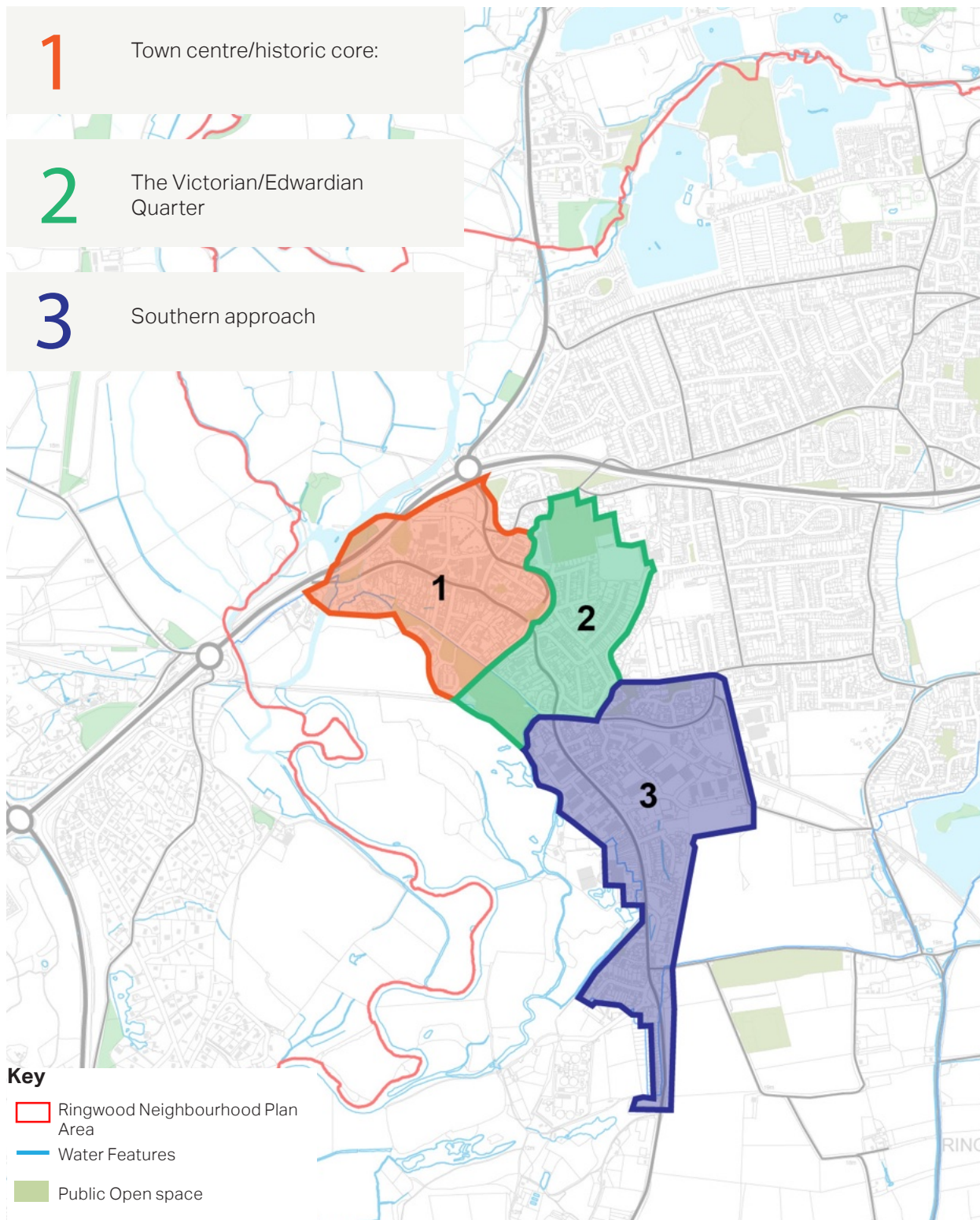

Figure 78: Ringwood character area map (The above 3 character areas are based on character areas 1, 2 and 5 of the Ringwood Local Distinctiveness SPD 2013)

Character area 1: Town centre/ historic core

Character Area 1, the historic core, includes most of the conservation area and town's main commercial and civic functions.

Land use is typical of a mixed use high street and adjoining streets, with shops, pubs, cafés and services alongside residential. This rich mix should be protected as essential to the function and character of the town. The accompanying masterplanning report includes a vision for improving the area's public spaces and some potential development opportunities.



Figure 80: Town centre/historic core Character Area Plan.

Locally distinctive features



Consistent roof line with brick chimney and a regular rhythm of front door and windows.



Varied roofscape in Market Pl looking north-west.



Some of the preserved older lanes remain throughout the town despite recent urban growth.

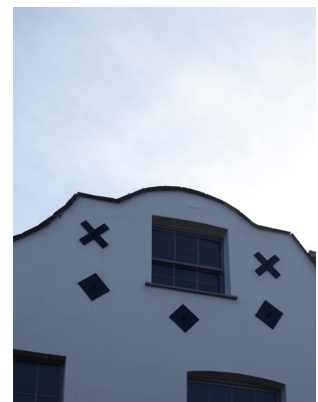

Some static features (cross bracing) on building's facade that emphasise the Town centre historic character



Fascia in buff alternated with red bricks



Local commemorative plaque on building facade



Thatched roof and timbered facade

Place-making

Morphology	Emphasise the existing street hierarchy, highlighting the primacy of the High Street within the town, but as a destination rather than a route. Also the historic character and the listed buildings should be preserved and enhanced. Respect the historic plots and reintroduce some historic paths.
Enclosure	Much of the historic core has a strong sense of enclosure and a ratio of 2:1 (e.g. The Furlong) to 1:3 (e.g. Market Place) should be generally maintained where that is the existing ratio.
Legibility and wayfinding	Distinctive landmark buildings, and their setting, should be protected. Listed buildings and important spaces, notably the Market Place, should be treated as landmarks, helping to engender a strong sense of place.
Extension and alteration	Many buildings in the area will be appropriate for rear extensions , subject to conservation area restrictions. These should follow the guidelines elsewhere in this document.
Public and private space	Maintain a clear distinction between private (shop frontages, courtyards) and public space (footpaths, streets, open space).
Views	Protect the views to Church of St Peter and St Paul and towards the millstream .

Building scale and form

Density	As a guide, housing development density should be around 30-40 dph (dwellings per hectare)
Typology	Terraced houses, town houses and low rise apartment blocks are an appropriate typology for the built up part of the town centre.
Building heights	Typically two-storey buildings with some at three storeys .
Building lines and set backs	Buildings should usually have no set back from the main street with a few set back occasionally . Building lines should be continuous and define a strong edge along the road.
Front and back garden	The existing building line suggests that front gardens are not to be expected in most of the historic core. Retain small front gardens where they exist, including the lanes off the High Street and Bickerley Road.
Active frontages	Buildings should have the front facing the street and promote active frontages onto the street or lane.

Materials and details

Materials	The use of high quality traditional red brick should be encouraged and plain clay tile and slate should be used for the roofscape within this zone.
Boundary treatment	Building walls should set right along the pavement with a discrete boundary treatment (low walls or a combination of low walls and railing) if a buffer is desired.

Green infrastructure

Open space	Protect and enhance the churtyard and the area's open spaces , most notably Bickerley Common . There is high potential for improvements to the Market Place -along the lines set out in the accompanying masterplan report.
Public realm	The quality of the street furniture as well as paving materials should be consistent with the existing (promote use of timber and metal) and spill out spaces should be encouraged - see accompanying masterplan report.

Access, movement and street design

Street typologies	Any changes to the High Street should respect that it has an important place function - as a destination and somewhere to linger - more so than for the simple movement of vehicles.
Pedestrian movement	The pavement width along the High Street should not be less than 2m where possible. 3 metres is ideal. Linkages from the shoppers' car parks to the High Street should be improved where possible.
Parking typologies	Courtyard parking for residential uses is usually appropriate in the central part of the character area.

Shop fronts

Signage

- i. The fascia is the most important area of a shopfront for advertising the business. Signage should be located within the established proportions and confines of the fascia board. Large box signs or additional flat boards should be avoided as they create disproportionate depth and height;
- ii. The most appropriate signage at fascia level is individual letters applied or painted directly onto the fascia board;
- iii. Hanging signs should be appropriately sized in relation to the building and street. They should not dominate the pavement space. They should use an appropriate material, shape, and form avoiding large box signs and they should not be illuminated;
- iv. Hanging signs should be held by slender, well-designed brackets using a high quality material; and
- v. In the case of corporate brands, those should be sensitive to the existing context, size and scale and use materials and textures from the local vernacular of the area.

Lighting

- i. Avoid using visually distinct sources of illumination that result in disproportionate signage, such as internally-illuminated box signs.

Safety

- i. Avoid using external roller shutters and grilles. Favour the use of internal open grilles which cover only the glazed part of the shop front; and
- ii. Conceal alarms from the shop front facade and integrate them discreetly within the shop front design or to the side of a building.

Character & Design

Integrate the shop front with the surrounding streetscape. Consider adjacent buildings and typical details in the area

Incorporate the overall proportion, form, and scale of the building's upper floors into the design of the shop front

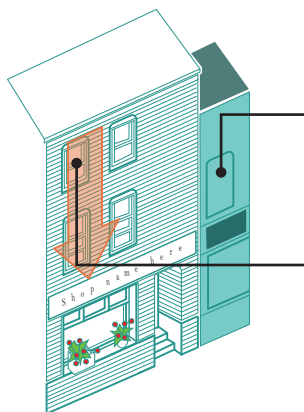

Lighting & Safety

Must avoid using internally-illuminated box signs

Conceal alarms from the shop front facade and integrate them in the design

Avoid using external roller shutters and grilles. Favour the use of internal open grilles which cover only the glazed part of the shop front

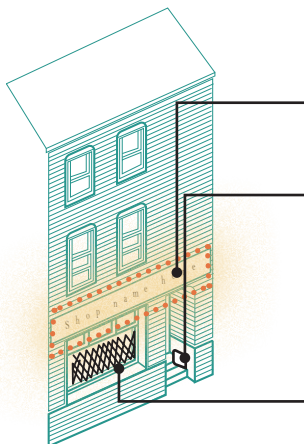

Signage

Avoid unnecessary visual clutter

Signage should not be placed on upper floors

Use the fascia as the predominant position for signage

Hanging signs should be in proportion to the building and street and should not dominate pavements

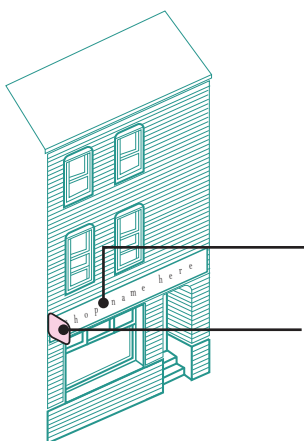

Good examples of shop front design

Stall riser

- i. A stall riser should be incorporated into the design for the full width of the shopfront, except for the door opening. The height of the stall riser should be between 0.3m and 1 m.

Materials

- ii. Window frames, doors, pilasters and fascias should be of timber construction with a painted finish, not a stained finish.

Panelling

- iii. Any timber panelling used in doors, stall risers, pilasters or other elements of the shop front should comprise a constructional timber panel and should not comprise the application of timber beading to a flat timber surface.

Fascia

- iv. The shop front design should include a full-width projecting fascia. The fascia should consist of a surrounding frame, creating an area for a shop-sign. Fascia with lettering of between 250mm and 300mm will read well from street level and from across the road; the size of the fascia is defined by the building typology or detailing, the font size should be proportionate to the fascia.

Lighting

- v. If lighting is incorporated into the design of the shop front, then it should comprise projecting light to create external illumination of the shop sign area.

Canopies

- vi. Promoting use of traditional extending canopies.

Shutters

- vii. If shutters and shutter boxes are incorporated into the design, then they should be placed internally, behind the shop front. When in an open position, shutters should not block the shop window opening; and
- viii. Flood defences for houses and shops should remain in place only as long as flood warnings are in place/ force.

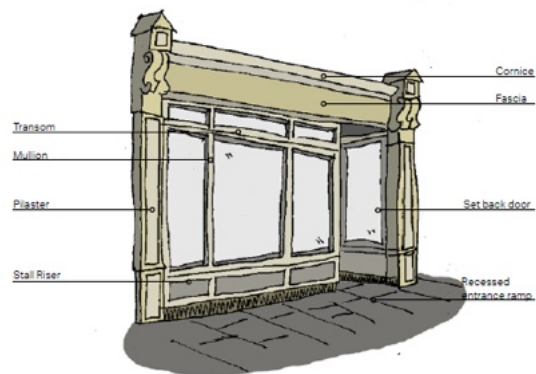

Figure 81: General principles of shop design.

Character area 2: Victorian/ Edwardian Quarter

Bookended by important green spaces, the Victorian/Edwardian Quarter is characterised by traditional residential streets with some small scale commercial and service uses.

The main building typologies are semi-detached with some detached and terraced houses, the latter found on the town centre approaches of Christchurch Road. The properties have generally small front gardens and larger back gardens.

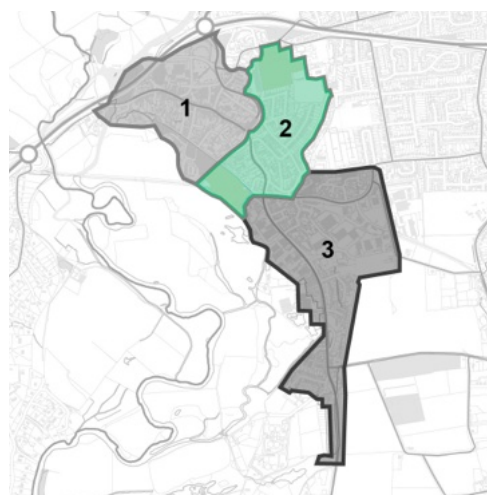

Figure 82: Victorian/Edwardian Quarter Zone Character Area.

Locally distinctive features



Consistent roof line with brick chimney and a regular rhythm of front door and windows.



Hung tiles side extension with exposed structure



Arc entrance with decorative red bricks details



Decorative white timber gate/fence



Roughcast rendered facade



Mix of timber frame with white painted bricks



Red bricks building with white cornerstone and inlets stone used as windows details



Ground floor in white painted bricks and mixed of roughcast and timber used for second floor

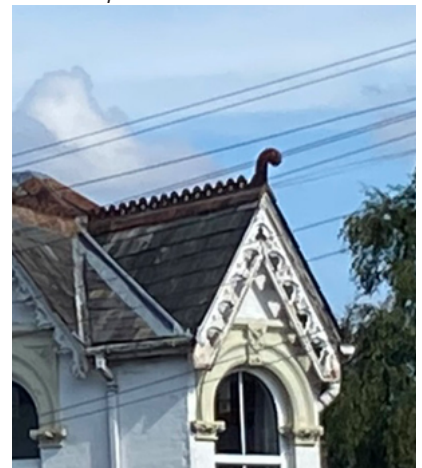

Gabled roof with bargeboard decorative details

Place-making	
Morphology	The morphology of this character area should reflect the alignment of the residential streets and their traditional pattern.
Enclosure	The enclosure ratio should typically be 1.1 to 1:2 .
Legibility and wayfinding	Trinity United Church and the almshouses on the Quomp act as landmarks in the character area, although the general quality of the housing stock and street greenery set the area apart from others in Ringwood.
Public and private space	A clear distinction between public and private space should be promoted with the use of boundary treatments.
Views	Maintain and respect the open views of Carvers and Bickerley .

Building scale and form	
Density	Density should be in the guide range of 25-35 dph .
Typology	Typologies to be used are: semi-detached, detached, and terraced houses .
Building lines and set backs	Overall properties should have a small to medium set back from the street, guided by the prevailing pattern. Building lines should be continuous along the road.
Front and back garden	Where they are included, future development should provide modest front gardens between 2 and 3m to provide a buffer and private amenity space .
Active frontages	Most of the properties should have standard proportion of fenestration overlooking streets .

Materials and details	
Roofs	The hipped and pitched roof should be encouraged in the area.
Aspect and orientation	Avoid blank façade towards open spaces and the Hight Street, Market PI and Christchurch Rd. Any future development should be designed to face open spaces and streets .
Building heights	Two-storey residential buildings should be encouraged.
Boundary treatment	Well-kept hedges, a mix of low wall and hedges .
Materials	Incorporating traditional brick, timber for walls, clay, tile or slate materials for roofscape should be encouraged along with the use of flint to respect the vernacular architecture .

Green infrastructure

Open space	The two public open spaces should be protected. The quality of these places should be promoted and improved where possible, as should the large back gardens on streets such as College Road and Nursery Road.
Public realm	Improve pedestrian environment in terms of safety and connections.

Access, movement and street design

Pedestrian movement	Whilst some of the most characterful streets do not have footways or includes them intermittently, streets should have footways on both sides where possible. They should be between 1.5m to 2m . Footpaths should be provided in any new development to increase the pedestrian safety.
Parking typologies	On-street, on-plot and courtyard parking should be encouraged.

Character area 3: Southern Approach

Set alongside Christchurch Road as it makes its way from the countryside to the more residential Victorian/Edwardian Quarter, southern approach is characterised by distinct housing areas amongst increasingly large format industrial and trading parks.

Like Castleman Way in the north of the character area, Christchurch Road is softened by street trees and small greens. It also includes some interesting red brick terraced housing

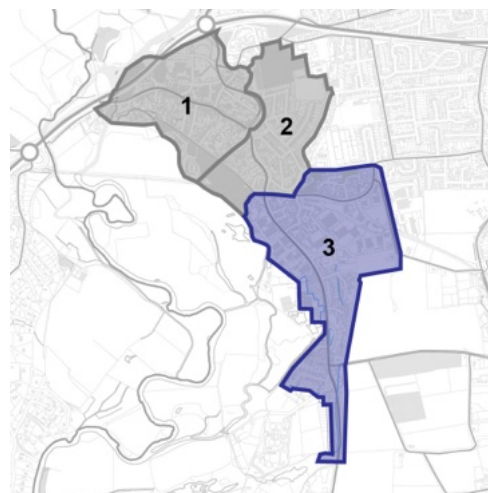

Figure 83: Southern Approach.

Locally distinctive features



Consistent roof line with brick chimney and a regular rhythm of front door and windows.



Red brick wall with hedges boundary treatment



Red bricks building with white cornerstone and inlets stone used as windows details



Hedges as boundary treatments



Fascia in buff alternated with red bricks



Ground floor in white painted bricks and mixed of roughcast and timber used for second floor

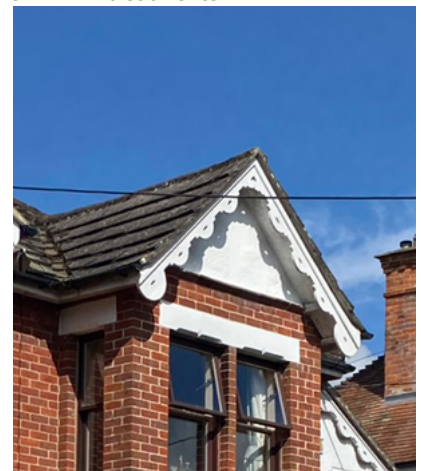

Gabled roof with bargeboard decorative details

Place-making	
Morphology	Housing and mixed use development should reflect linear nature of the approach towards the town centre, whilst employment development should reference the human-scale of the rest of Ringwood and its traditional pattern.
Enclosure	The enclosure ratio should reflect prevailing patterns in industrial areas. Where bungalows are predominant, a ratio of 1:3 is suggested, while a ratio of 1:2 is advised for the remaining residential areas.
Legibility and wayfinding	The red brick housing and greens on Christchurch Road are landmarks in the character area, marking an urban-rural transition. Opportunities for improving wayfinding in the new industrial areas should be grasped.
Public and private space	A clear distinction between public and private space should be promoted with the use of boundary treatments.
Views	The most valued views are into the character area from the west .

Building scale and form	
Density	Housing density should be in the guide range of 25-35 dph .
Typology	Predominant housing typology to be used is terraced housing , or appropriate (according to context) infill .
Building lines and set backs	Overall properties should have a small to medium set back from the street, guided by the prevailing pattern. Building lines should be continuous along the road.
Front and back garden	Where they are included, future development should provide modest front gardens between 2 and 3m to provide a buffer and private amenity space .
Active frontages	Employment buildings should have glazed facades facing streets .

Materials and details	
Roofs	The hipped and pitched roof should be encouraged in the area. Steep gables are appropriate here.
Aspect and orientation	Avoid black façades and inward facing development , particularly in employment areas.
Building heights	Two-storey residential buildings should be encouraged.
Boundary treatment	Well-kept hedges, a mix of low wall and hedges .
Materials	Locally used materials, such as traditional brick and render , should be considered.

Green infrastructure

Open space	The small greens must be protected, and new employment buildings to the east of Christchurch Road require a green setting.
Public realm	The area should not be simply designed to facilitate the movement of vehicles.

Access, movement and street design

Pedestrian movement	Opportunities for improving the walking environment , including footways on both sides of streets, should be taken where practical. This is particularly important on the industrial areas to the west of Christchurch Road, which have a very poor pedestrian environment.
Parking typologies	On-plot and courtyard parking should be encouraged. Parking for employment uses must not dominate the streetscene and should be behind or beside the building where possible.

Design for large scale employment and commercial

For large-scale, non-residential development such as offices, industrial, retail, cinema multiplexes or warehouses, understanding the context of the site and attention to detail and build quality are just as important as with residential applications, particularly because they tend to be large structures or 'big boxes' and often on greenfield sites.

Sustainable design

New development should incorporate sustainable building design through measures to minimise the need for energy and water consumption, encourage recycling, minimise waste, and use sustainable construction methods.

As well as considering energy efficiency and building fabric from the outset, new buildings offer the potential to include solar panels as sources of renewable energy for heating and electricity, and green roofs offer multiple benefits such as absorption of rainwater, insulation, wildlife habitat, mitigating the heat island effect and providing an aesthetically pleasing landscape. Sustainable drainage systems should be incorporated.

New industrial or commercial development should also encourage travel by sustainable modes of transport – on foot, by bike or by public transport. Whilst industrial sites have not traditionally been very accessible by these modes, new sites will need to respond to the climate emergency. A reduction in car use can be achieved by:

- Providing convenient, short, direct routes to the main entrances;
- Ensuring the development is directly served by adequate public transport services;
- Providing secure covered cycle stores near entrances and adjacent to overlooking windows;
- Providing changing and showering facilities for cyclists;
- Providing on- and off-site cycleways to enable connection to the area's wider cycle network;
- Providing green infrastructure – in particular the use of appropriate tree species to improve local air quality;
- Providing electric vehicle recharging infrastructure within car parks and for commercial vehicles (where appropriate); and
- Preparing staff travel plans.

Frontages

The siting and design of new buildings should maximise surveillance along streets, car parks and pedestrian routes. Buildings should be sited to allow windows and entrances to overlook streets and other pedestrian routes within or adjacent to the site. New industrial and commercial plots will be expected to front buildings onto the public realm and to enclose 'private' external spaces such as yards and car parks, behind them.

Particular care should be taken with 'big box' structures which typically have limited active frontages. The use of windows, materials (such as green walls) and architectural detailing can be used to add interest to what might otherwise be large, blank façades, and locate entrances, glass façades, cafeterias, offices or signage along the street frontage. Any windows should face the street and public areas.

Landscape screening

Landscaping can be a key element in the design of a scheme and should go beyond simply being used for screening. Landscape elements should be integrated from the outset, particularly SuDS features.

Good opportunities exist for creating commercial developments with landscaping schemes that knit a development into its particular landscape setting. Existing tree belts and hedgerows can be important features around which to structure the layout of new development. Their retention can be essential in locations where industrial development can be seen from distant public viewpoints and the existing landscape setting needs to be protected or enhanced. Retained features should be suitably protected during the construction period.

Planting can be used to help improve the relationship of the building with the street, to soften the visual impact of the building

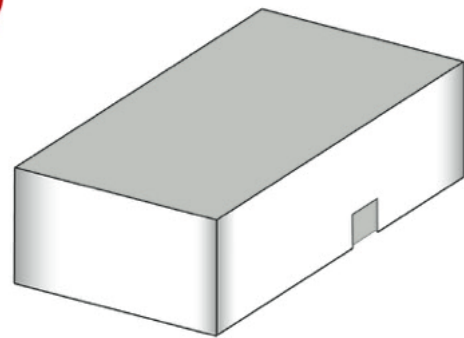
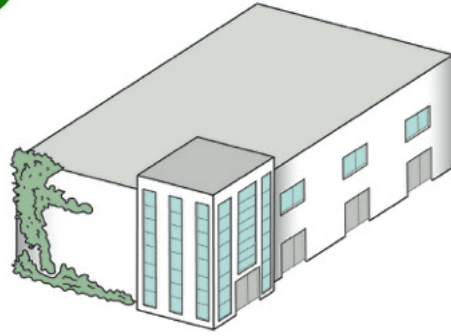

Frontages - even 'big boxes' should have a public face to present.

and also the parking and servicing areas which can often be large areas of hard landscaping. Smaller buildings can also be wrapped around larger buildings to help soften their visual impact. Alternatively, buildings can be designed to celebrate or sit comfortably in their setting.

Parking and servicing

Locate landscaped parking and servicing areas to the rear or side where possible to avoid these areas dominating the street scene and/or the plot. Trees should be incorporated into parking areas.

Within employment and commercial areas, areas of communal parking are encouraged to meet the demand from users of a number of buildings. Car parks should be designed with pedestrians and cyclists in mind, with clear, direct and safe routes separating them from vehicles and external lighting.

Charging points for electric cars should be provided.

Trees in parking areas will need high quality underground provision for roots to grow in order for them to survive and flourish.

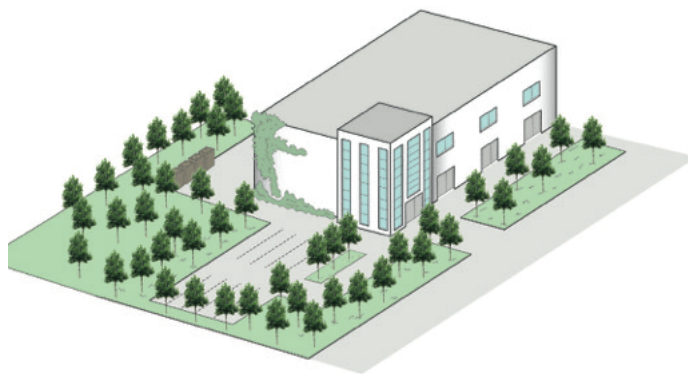

Parking screened to the side, servicing to the rear.



The headquarters of furniture manufacturer Vitra, in Germany, demonstrate that striking architecture and strong landscape can sit proudly in a sensitive environment. The building shown is a showroom.

Architecture

New buildings should be of high quality, contemporary design, appropriate for the use and context. The design of any building, even the simplest industrial shed, should always make some positive visual contribution to its environment. Local materials can be used on larger or non-domestic buildings.

Contemporary and innovative architecture that subtly references local character is encouraged. The visual impact of colours and finishes of wall and roof cladding materials should be considered in relation to the background and context of the building. Their impact on the townscape or landscape should also be assessed in long views and views from higher ground.

Generally, more subdued and non-reflective finishes will reduce the overall impact of a building. Colour contrast and highly reflective materials may be used to highlight key features such as entrances, windows and structure. However, where a landmark building is considered appropriate, the use of contrasting materials and colours may be justified.

The impact of new buildings on neighbouring properties in terms of their effect on sunlight and on daylight should be minimised. The use of out-of-hours night time lighting should be minimised, which also benefits wildlife such as bats. Where lighting is required for security and/or community safety, downward directed, vandal resistant, energy efficient light units should be installed. Increased light pollution from car park and security lighting may cause disturbance to the local community. Lighting should not be placed next to wildlife habitats.



Checklists

05

5. Checklists

5.1 Checklists

Because the design guidance and codes in this document cannot cover all design eventualities, this chapter provides a number of questions based on established good practice against which the design proposal should be evaluated. The aim is to assess all proposals by objectively answering the questions below. Not all the questions will apply to every development. The relevant ones, however, should provide an assessment as to whether the design proposal has taken into account the context and provided an adequate design solution.

As a first step there are a number of ideas or principles that should be present in all proposals. These are listed under "General design guidance for new development." Following these ideas and principles, a number of questions are listed for more specific topics on the following pages.

1

General design guidance for new development:

- Integrate with existing paths, streets, circulation networks and patterns of activity;
- Reinforce or enhance the established settlement character of streets, greens, and other spaces;
- Harmonise and enhance existing settlement in terms of physical form, architecture and land use;
- Relate well to local topography and landscape features, including prominent ridge lines and long-distance views;
- Reflect, respect, and reinforce local architecture and historic distinctiveness;
- Retain and incorporate important existing features into the development;
- Respect surrounding buildings in terms of scale, height, form and massing;
- Adopt contextually appropriate materials and details;
- Provide adequate open space for the development in terms of both quantity and quality;
- Incorporate necessary services and drainage infrastructure without causing unacceptable harm to retained features;
- Ensure all components e.g. buildings, landscapes, access routes, parking and open space are well related to each other;
- Make sufficient provision for sustainable waste management (including facilities for kerbside collection, waste separation, and minimisation where appropriate) without adverse impact on the street scene, the local landscape or the amenities of neighbours;
- Positively integrate energy efficient technologies;
- Ensure that places are designed with management, maintenance and the upkeep of utilities in mind; and
- Seek to implement passive environmental design principles by, firstly, considering how the site layout can optimise beneficial solar gain and reduce energy demands (e.g. insulation), before specification of energy efficient building services and finally incorporate renewable energy sources.

2

Street grid and layout:

- Does it favour accessibility and connectivity? If not, why?
- Do the new points of access and street layout have regard for all users of the development; in particular pedestrians, cyclists and those with disabilities?
- What are the essential characteristics of the existing street pattern; are these reflected in the proposal?
- How will the new design or extension integrate with the existing street arrangement?
- Are the new points of access appropriate in terms of patterns of movement?
- Do the points of access conform to the statutory technical requirements?

3

Local green spaces, views and character:

- What are the particular characteristics of this area which have been taken into account in the design; i.e. what are the landscape qualities of the area?
- How does the proposal affect the trees on or adjacent to the site?
- Can trees be used to provide natural shading from unwanted solar gain? i.e. deciduous trees can limit solar gains in summer, while maximising them in winter.
- Has the proposal been considered within its wider physical context?
- Has the impact on the landscape quality of the area been taken into account?
- In rural locations, has the impact of the development on the tranquillity of the area been fully considered?
- How does the proposal impact on existing views which are important to the area and how are these views incorporated in the design?
- Can any new views be created?
- Is there adequate amenity space for the development?
- Does the new development respect and enhance existing amenity space?
- Have opportunities for enhancing existing amenity spaces been explored?

3

Local green spaces, views and character:

- Will any communal amenity space be created? If so, how this will be used by the new owners and how will it be managed?
- Is there opportunity to increase the local area biodiversity?
- Can green space be used for natural flood prevention e.g. permeable landscaping, swales etc.?
- Can water bodies be used to provide evaporative cooling?
- Is there space to consider a ground source heat pump array, either horizontal ground loop or borehole (if excavation is required)?

4

Gateway and access features:

- What is the arrival point, how is it designed?
- Does the proposal maintain or enhance the existing gaps between settlements?
- Does the proposal affect or change the setting of a listed building or listed landscape?
- Is the landscaping to be hard or soft?

5

Buildings layout and grouping:

- What are the typical groupings of buildings?
- How have the existing groupings been reflected in the proposal?
- Are proposed groups of buildings offering variety and texture to the townscape?
- What effect would the proposal have on the streetscape?
- Does the proposal maintain the character of dwelling clusters stemming from the main road?
- Does the proposal overlook any adjacent properties or gardens? How is this mitigated?
- Subject to topography and the clustering of existing buildings, are new buildings oriented to incorporate passive solar design principles, with, for example, one of the main glazed elevations within 30° due south, whilst also minimising overheating risk?
- Can buildings with complementary energy profiles be clustered together such that a communal low carbon energy source could be used to supply multiple buildings that might require energy at different times of day or night? This is to reduce peak loads. And/or can waste heat from one building be extracted to provide cooling to that building as well as heat to another building?

6

Building line and boundary treatment:

- What are the characteristics of the building line?
- How has the building line been respected in the proposals?
- Has the appropriateness of the boundary treatments been considered in the context of the site?

7

Building heights and roofline:

- What are the characteristics of the roofline?
- Have the proposals paid careful attention to height, form, massing and scale?
- If a higher than average building(s) is proposed, what would be the reason for making the development higher?
- Will the roof structure be capable of supporting a photovoltaic or solar thermal array either now, or in the future?
- Will the inclusion of roof mounted renewable technologies be an issue from a visual or planning perspective? If so, can they be screened from view, being careful not to cause over shading?

8

Household extensions:

- Does the proposed design respect the character of the area and the immediate neighbourhood, and does it have an adverse impact on neighbouring properties in relation to privacy, overbearing or overshadowing impact?
- Is the roof form of the extension appropriate to the original dwelling (considering angle of pitch)?
- Do the proposed materials match those of the existing dwelling?
- In case of side extensions, does it retain important gaps within the street scene and avoid a 'terracing effect'?
- Are there any proposed dormer roof extensions set within the roof slope?
- Does the proposed extension respond to the existing pattern of window and door openings?
- Is the side extension set back from the front of the house?
- Does the extension offer the opportunity to retrofit energy efficiency measures to the existing building?
- Can any materials be re-used in situ to reduce waste and embodied carbon?

9

Building materials and surface treatment:

- What are the distinctive materials in the area?
- Do the proposed materials harmonise with the local materials?
- Does the proposal use high-quality materials?
- Have the details of the windows, doors, eaves and roof details been addressed in the context of the overall design?
- Do the new proposed materials respect or enhance the existing area or adversely change its character?
- Are recycled materials, or those with high recycled content proposed?
- Has the embodied carbon of the materials been considered and are there options which can reduce the embodied carbon of the design? For example, wood structures and concrete alternatives.
- Can the proposed materials be locally and/or responsibly sourced? E.g. FSC timber, or certified under BES 6001, ISO 14001 Environmental Management Systems?

10

Car parking:

- What parking solutions have been considered?
- Are the car spaces located and arranged in a way that is not dominant or detrimental to the sense of place?
- Has planting been considered to soften the presence of cars?
- Does the proposed car parking compromise the amenity of adjoining properties?
- Have the needs of wheelchair users been considered?
- Can electric vehicle charging points be provided?
- Can secure cycle storage be provided at an individual building level or through a central/communal facility where appropriate?
- If covered car ports or cycle storage is included, can it incorporate roof mounted photovoltaic panels or a biodiverse roof in its design?

11

Architectural details and design:

- If the proposal is within a Conservation Area, how are the characteristics reflected in the design?
- Does the proposal harmonise with the adjacent properties? This means that it follows the height massing and general proportions of adjacent buildings and how it takes cues from materials and other physical characteristics.
- Does the proposal maintain or enhance the existing landscape features?
- Has the local architectural character and precedent been demonstrated in the proposals?
- If the proposal is a contemporary design, are the details and materials of a sufficiently high enough quality and does it relate specifically to the architectural characteristics and scale of the site?
- Is it possible to incorporate passive environmental design features such as larger roof overhangs, deeper window reveals and/or external louvres/shutters to provide shading in hotter months?
- Can the building designs utilise thermal mass to minimise heat transfer and provide free cooling?
- Can any external structures such as balconies be fixed to the outside of the building, as opposed to cantilevering through the building fabric to reduce thermal bridge?



Delivery

06

6. Delivery

6.1 Delivery

The design guidance and codes will be a valuable tool in securing context-driven, high-quality development in Ringwood. They will be used in different ways by different actors in the planning and development process, as summarised in the table.

Actors	How They Will Use the Design Guidance and Codes
Applicants, developers, and landowners	As a guide to community and Local Planning Authority expectations on design, allowing a degree of certainty – they will be expected to follow the code as planning consent is sought.
Local Planning Authority	As a reference point, embedded in policy, against which to assess planning applications. The code should be discussed with applicants during any pre-application discussions.
Town Council	As a guide when commenting on planning applications, ensuring that the code is complied with.
Community organisations	As a tool to promote community-backed development and to inform comments on planning applications.
Statutory consultees	As a reference point when commenting on planning applications.

About AECOM

AECOM is the world's trusted infrastructure consulting firm, delivering professional services throughout the project lifecycle — from planning, design and engineering to program and construction management. On projects spanning transportation, buildings, water, new energy and the environment, our public- and private-sector clients trust us to solve their most complex challenges. Our teams are driven by a common purpose to deliver a better world through our unrivaled technical expertise and innovation, a culture of equity, diversity and inclusion, and a commitment to environmental, social and governance priorities. AECOM is a *Fortune 500* firm and its Professional Services business had revenue of \$13.2 billion in fiscal year 2020. See how we are delivering sustainable legacies for generations to come at aecom.com and [@AECOM](https://www.instagram.com/AECOM).